



## Design and implementation of a cost-aware and smart oyster mushroom cultivation system

Abdullah Elewi<sup>a,\*</sup>, Abdulsalam Hajhamed<sup>b</sup>, Rasheed Khankan<sup>c</sup>, Sonay Duman<sup>a</sup>, Amina Souag<sup>d</sup>, Asma Ahmed<sup>e</sup>

<sup>a</sup> Computer Engineering Department, Mersin University, Mersin 33343, Turkey

<sup>b</sup> Faculty of Agricultural Sciences, University of Hohenheim, Stuttgart 70599, Germany

<sup>c</sup> Electrical and Electronic Engineering Department, Mersin University, Mersin 33343, Turkey

<sup>d</sup> School of Engineering, Technology and Design, Canterbury Christ Church University (CCCU), Canterbury, United Kingdom

<sup>e</sup> Department of Chemical and Environmental Engineering, University of Nottingham, Nottingham NG7 2RD, United Kingdom

### ARTICLE INFO

#### Keywords:

Mushroom cultivation

Smart farming

Smart agriculture

Remote monitoring and management (RMM)

Internet of Things (IoT)

ThingSpeak™

### ABSTRACT

Mushrooms are a nutritious food source, which can play a crucial role in providing affordable sources of proteins, vitamins and minerals for people worldwide, but their cultivation requires extensive training and considerable relevant expertise in order to fine-tune multiple environmental parameters.

Internally displaced people in the Northern regions of Syria rely on very small-scale traditional oyster mushroom production, which cannot meet their local demand. Many international and local non-governmental organizations (NGOs) working for Syrian refugees, work on mushroom cultivation projects. They have reported significant difficulties and challenges in mushroom cultivation amongst the targeted beneficiaries. Therefore, the two main questions driving this research are: (1) How can organic mushroom cultivation be promoted using a robust and affordable intelligent mushroom farming system? (2) How can organic mushroom farming practices be simplified to support internally displaced and refugee Syrians?

This research evaluates the process of automating mushroom cultivation by designing and implementing a smart oyster (*Pleurotus ostreatus*) mushroom farming system to remotely monitor and manage environmental parameters, such as temperature, humidity, air quality and illumination, inside the farm. Furthermore, ready and dedicated user-friendly web interfaces were also implemented to enable farmers to remotely monitor and manage their farms through the Internet. As a result, a dependable and cost-effective intelligent oyster mushroom cultivation system was designed and implemented in this work. The system includes remote monitoring and management via user-friendly interfaces. This simplifies mushroom cultivation for not only refugees and displaced communities, but also for mushroom farmers in low-income countries. This work can contribute to the eradication of poverty and hunger, in line with the United Nations Sustainable Development Goals one and two.

### 1. Introduction

Mushrooms are a valuable food source, rich in proteins, fibre, antioxidants, and a variety of vitamins and minerals. However, their cultivation requires extensive training and considerable relevant expertise in order to fine-tune multiple environmental parameters [8]. These parameters are heat, humidity, illumination, and ventilation, and they should be controlled precisely for successful mushroom cultivation. Otherwise, the mushroom yield will be adversely affected or contaminated. The tragic conflict in Syria during the last decade caused the

migration of many skilled farmers and a great loss of cultivated territories. Furthermore, the COVID-19 pandemic and its resulting international economic crises, such as supply chain crisis, have exacerbated these bad situations, threatening food security and adequate nutrition sources.

Many Syrian refugees in neighbouring countries are working in agriculture and are involved in small/medium-scale mushroom production industry. For example, a large number of mushroom farms are operated by Syrian refugees in Turkey, where the total Turkish mushroom production was 55,455 tons in 2020 [19]. An 85 m<sup>2</sup> mushroom oyster farm/greenhouse with a capacity of 1000×10-kg bags in Turkey

\* Corresponding author.

E-mail address: [elewi@mersin.edu.tr](mailto:elewi@mersin.edu.tr) (A. Elewi).

<https://doi.org/10.1016/j.atech.2024.100439>

Received 26 December 2023; Received in revised form 29 February 2024; Accepted 17 March 2024

Available online 18 March 2024

2772-3755/© 2024 The Authors. Published by Elsevier B.V. This is an open access article under the CC BY license (<http://creativecommons.org/licenses/by/4.0/>).

can produce about 2700–3000 kg of mushroom every cycle. On the other hand, internally displaced Syrians in the Northern regions of Syria rely on very small-scale traditional mushroom production, which cannot meet their local demand. For example, a  $3 \times 4 \text{ m}^2$  conventional oyster mushroom farm in these regions can produce about 300–400 kg every cycle. Moreover, imported mushrooms are not readily available and would be unaffordable. To the best of our knowledge, no accurate statistics are available for the Syrian mushroom industry.

Many international and local Non-Governmental Organizations (NGOs), such as the International Agricultural Cooperation Organization (IACO) and *Shafak*, working for Syrian refugees, have mushroom cultivation projects. They have reported significant difficulties and challenges in mushroom cultivation amongst the targeted beneficiaries, mostly housewives, even after providing them with materials and preliminary training, due to the complexities of controlling the environment [5]. These difficulties and challenges result in high failure rates amongst insufficiently experienced growers when trying to handle the multiple interfering environmental factors affecting and contaminating mushrooms.

These reasons were the motivation behind this study to design and implement a smart, affordable mushroom cultivation system, which simplifies the mushroom production process for organic mushroom farmers, especially for internally displaced and refugee Syrians.

Smart farming generally utilizes various information and communication technologies (ICT) [21] for sustainable agriculture to save resources and improve the efficiency and the yield of the farm through remote monitoring and management [22]. Many recent surveys [1,6,7] have reviewed smart agriculture techniques, opportunities and challenges for various types of agriculture and crops. For mushroom cultivation, traditional methods have been used for a long time, but incorporating state-of-the-art technologies for monitoring and controlling the cultivation process has been recently investigated.

Smart technologies were introduced to mushroom cultivation quite recently, especially for small and medium-scale mushroom production. Angral and Thakur [2] classified current mushroom-growing systems into Programmable Logic Controller- (PLC)-based, microcontroller-based and IoT-based systems. However, this paper did not illustrate either the IoT platform or the data acquisition tools used for this work. Thong-un and Wongsaraj [17] used smart wireless industrial PLC for wireless monitoring, controlling, and propagating information to a database in order to enhance oyster mushroom productivity in Thailand. The wireless PLC node reads the different environmental parameters, such as temperature and humidity, through sensors to control spraying, water sprinkles and cooling fans. Onsite and remote monitoring and control of the mushroom farming system were available through onsite human-machine interface (HMI) screens or web applications. The system architecture, components, and working method are well explained and illustrated, but the effect of carbon dioxide (CO<sub>2</sub>) and air quality inside the mushroom farm was not discussed in this work. Another similar system was developed in Malaysia by Ten et al. [16] for an automated controlled environment mushroom house (CEMH) using remote terminal unite, ADAM-3600, internet of things (IoT) technologies and different sensors for temperature, humidity, light and CO<sub>2</sub>. These two systems have proven to be dependable industrial systems, but their cost is relatively high. Similar industrial systems for automating a one-room mushroom farm could cost about \$1500-\$2000 in Turkey, excluding the set-up and online software costs of the system.

Other cost-efficient solutions using inexpensive microcontrollers and sensors are also available. Some of these systems [10,11,14,15] were only used for monitoring the mushroom farm, while others [8,12] provided remote monitoring in addition to management and control of the farm. Inexpensive off-the-shelf sensors were utilized for humidity, temperature, CO<sub>2</sub> and light, such as DHT11, DHT22, LM35, MQ135 and BH1750 sensors. The NodeMCU (ESP8266) was mostly used for connecting to the internet, while Arduino platforms were mostly utilized as controllers. Existing software products, such as Blynk and ThingSpeak, were mostly used for remote access and monitoring. The main problem

with such inexpensive systems, which could cost about \$100-\$150, is related to dependability as most of these proposed systems were not tested in real environments. Conversely, He et al. [4] constructed not only the remote monitoring and management (RMM) system but also the whole mushroom cultivation farm in a dedicated container with  $3 \text{ m} \times 3 \text{ m} \times 9 \text{ m}$  dimensions. They built a Controlled Environment Agriculture (CEA) system to provide fresh crops in urban areas, but they did not take the cost and yield of such container farms into account.

Recently, emerging technologies of computer vision (CV) and machine learning (ML) have been used in mushroom cultivation for different purposes, such as the classification of mushroom spawn quality [18] and mushroom caps measurement [9]. Yin et al. [20] have surveyed different computer vision and machine learning technologies used in the mushroom industry reviewing related papers between 1991 and 2021. Recent related research [12] has implemented a mushroom automation system using a sensing module (BME260) for humidity and temperature, ESP8266 for wireless connection and ESP32 SoC as a controller, which gets the environmental parameters from the sensing module to control the mushroom farm automation. They also utilized a camera module with machine learning algorithms implemented on Raspberry Pi for classifying toxic mushrooms.

Thus, the existing mushroom cultivation systems are either expensive industrial systems or unreliable inexpensive ones. Additionally, CV and ML technologies have shown promise in smart mushroom cultivation and could provide extra functionalities, such as disease detection, yield prediction, growth analysis and cost/power efficiency, if edge computing (EC) and digital twinning were included to provide an affordable dependable mushroom cultivation system with full remote access and monitoring [20].

Against this backdrop, the goal of this study was to deploy state-of-the-art emerging technologies, such as the Internet of Things (IoT) and Artificial Intelligence (AI) techniques, for acquiring and analysing data from different sensors and cameras to remotely monitor and control the environmental conditions inside the mushroom farm, and for future research on growth analysis and disease detection problems. The main contributions of this paper include designing and implementing three different sensing nodes with different costs, in addition to two different control nodes to be affordable for various mushroom farmers. Furthermore, simple web and desktop user-friendly interfaces were implemented to facilitate the remote monitoring and management of the farm. Finally, an analysis of sensing node readings and obtained results has been made.

## 2. Materials and methods

The proposed mushroom cultivation system can generally be divided into three main layers shown in Fig. 1: The first layer is the monitoring/controlling physical layer, which is composed of sensors for environmental data acquisition, such as temperature, humidity, soil/composite temperature, composite moisture, air quality, CO<sub>2</sub>, illuminance, and cameras. Besides the sensors, there are actuators for controlling the different devices of the farm, such as air conditioners, humidifiers, sprinklers, extractor fans, and circulating fans. The second layer is composed of the edge boards, which regulate the data acquisition process and perform the required processing for precise and efficient controlling of the farm actuators. At the same time, they provide a connection to the cloud which constitutes the third layer of the proposed system, where different types of data ultimately exist.

The system is designed on the assumption that the farm is equipped with the necessary devices and infrastructure for oyster mushroom cultivation. Additionally, an electrical power source and internet access were available at the farm. In a situation where this may not be the case, alternative power and internet solutions will be required for the system to be implemented. For example, in off-grid rural areas, alternative power sources such as solar energy systems can be used to provide electricity, as is commonly done in off-grid areas in Northern Syria nowadays. To access the internet, mobile and satellite internet

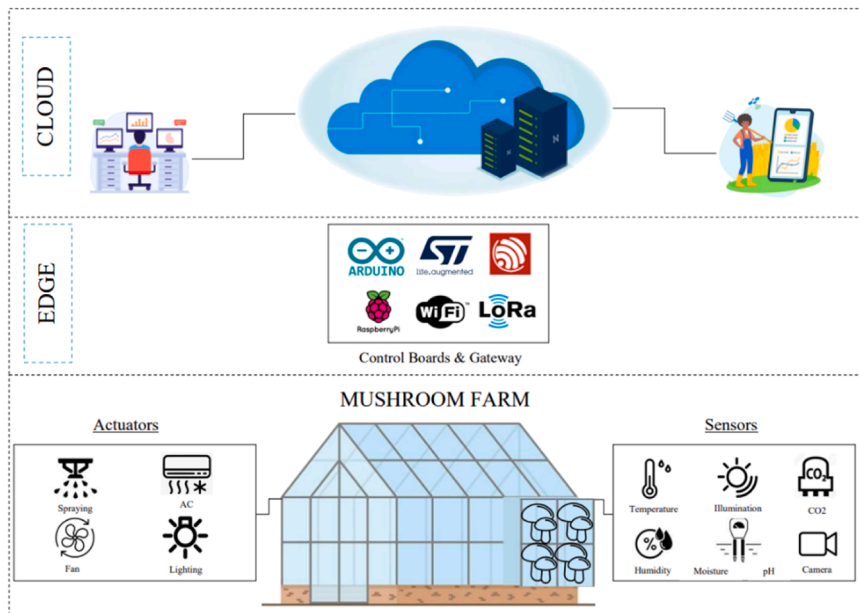

Fig. 1. General architecture of smart mushroom cultivation system.

connections can be used.

Fig. 2 shows a more specific block diagram of the proposed system, which is composed of sensors, actuators, and microcontrollers connected to an IoT platform. The sensors are used for monitoring the main environmental parameters, such as temperature, relative humidity, composite temperature, composite moisture, air quality, CO<sub>2</sub>, and illuminance. Besides, different cameras are utilized for monitoring the farm and capturing images to be used in future research for growth analysis using AI and ML techniques. Actuators manage and control the farm

devices, such as air conditioners, humidifiers, and fans. Furthermore, the system utilizes ThingSpeak as an IoT platform for remote monitoring and management.

The proposed system was implemented and tested in a local oyster mushroom farm in Mersin, on Turkey’s Mediterranean coast. Generally, the climate is mild and wet in winter, with temperatures ranging between 8 and 15 °Celsius, and it becomes hot and humid in summer, with temperatures around 30 °Celsius. The farm has 14×7 m<sup>2</sup> area and a maximum capacity of 1000 of 10-kg mushroom bags, on its 4-storey

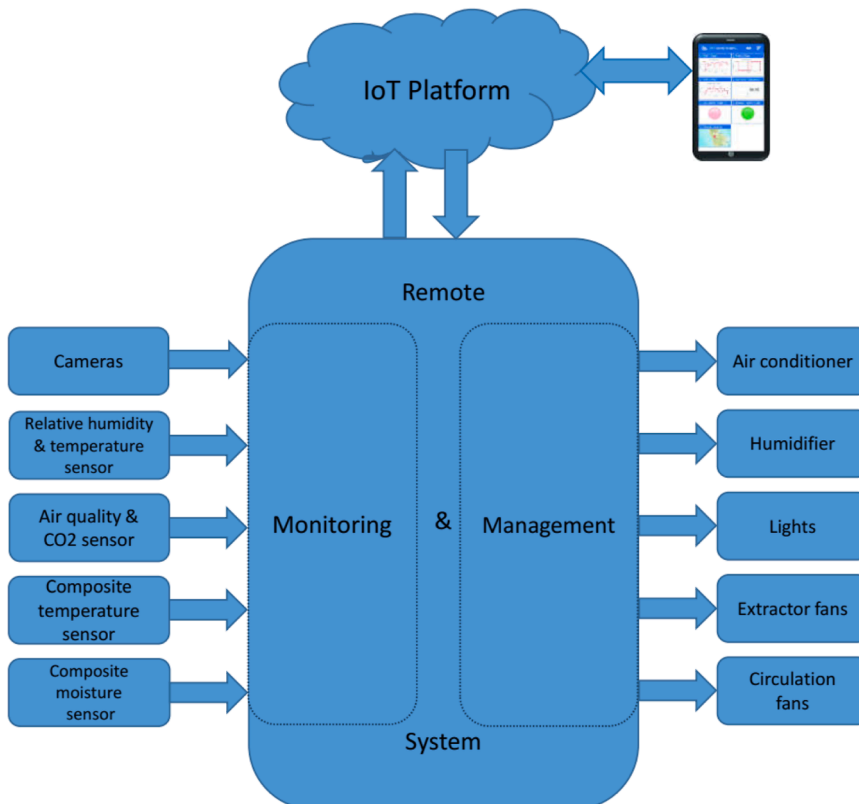

Fig. 2. Mushroom cultivation system block diagram.

shelves. Different types of sensing nodes were implemented and tested in the farm. The experiments were conducted for two cultivation cycles starting from late December 2022 until late April 2023. Different free IoT platforms, such as Blynk, Arduino IoT and ThingSpeak, were trialled. Blynk and Arduino IoT platforms offer user-friendly platforms with very limited capabilities for the free version. However, a free account on the ThingSpeak platform provides higher capabilities and allows 10 million messages a year with 3 years of data storage. ThingSpeak permits instant visualizations of data posted by the farm sensors, such as temperature, relative humidity, and soil moisture data, which can be remotely monitored. Additionally, it shows the On/Off status of remotely controlled devices, and can perform data analysis and processing with all MATLAB™ capabilities. Thus, it can present an efficient IoT system for the mushroom farm without the need to set up servers or develop dedicated web software. All of these made ThingSpeak more preferable for the system addressed here.

### 2.1. Sensing nodes

To provide remote monitoring of the farm, various types of sensors with different prices and capabilities were trialled. Two different temperature/humidity sensors were utilized: DHT21 and SHT20, which measure the relative humidity and temperature of the farm. The DS18B20 was the most suitable choice for measuring the composite temperature inside mushroom bags because of its thermocouple principle and well insulation. For composite moisture, the two tested types are capacitive and resistive moisture sensors. For air quality and CO<sub>2</sub> measuring, three different types of sensors, SGP30, CCS811, and MH-Z19, were trialled. Finally, the BH1750 was used as an illuminance sensor.

Another important component for these sensors to work is the microcontroller boards which regulate the data acquisition process from sensors, and perform the required calculations for precise controlling of the actuators. Since one of the main targets was the design and implementation of an affordable monitoring/control system, the most appropriate microcontrollers were ESP8266 and ESP32 due to their affordable price and available capabilities, such as Bluetooth, Wi-Fi and I2C.

The cost of the proposed system was a critical consideration in the project due to targeted users, refugees and displaced communities. Therefore, three different sensing nodes with low, medium and high costs were designed and implemented (Figs. 3-5) in order to compare their performance to choose the most appropriate product at an affordable cost. Every sensing node was associated with a ThingSpeak channel to monitor the sensor readings instantly in addition to saving historical sensor data to be analysed later. The prices of all utilized components in this study are offered in Table 1 according to 2023 prices in Turkey, including 20 % value-added tax.

The lowest-cost sensing node consists of a microcontroller board and three sensors shown in Fig. 3. This node contains the NodeMCU ESP8266 development board, which is the cheapest amongst the family of microcontrollers that can connect to the Internet. It also contains the minimum number of general input/output pins (GPIOs) that can operate the sensors necessary to read environmental parameters. It contains one analogue input which enables us to read the analogue value of the capacitive soil moisture sensor. Also, we can easily connect the composite temperature sensor DS18B20 which works on 1-wire protocol and the DHT21 temperature/humidity sensor which works also on 1-wire protocol. We utilized a DC-to-DC converter (LM2596) to provide more accurate voltage values for sensors from a voltage adaptor. The node worked well with a margin of inaccuracy, especially with high humidity values. Fig. 3 shows the detailed schematic diagram that shows how these three sensors are connected, and to which pins, for the lowest-cost sensing node. Furthermore, all source code files and an instructional document are also provided as supplementary material.

The medium-cost node, illustrated in Fig. 4, consists of ESP32 WROOM 32D as a development board, DHT21 as a temperature/humidity sensor, DS18B20 as a soil temperature sensor, capacitive soil

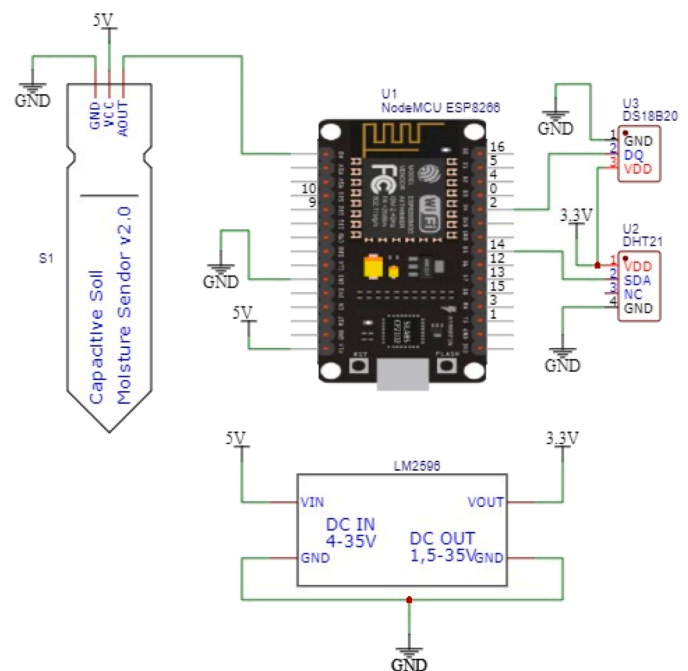

Fig. 3. Lowest-cost sensing node.

Table 1  
Utilized component prices.

Component	Price (\$)
NodeMCU ESP 8266 board	4.90
ESP32 WROOM 32D board	7.22
DHT21 Temperature/humidity sensor	3.87
SHT20 Temperature/humidity sensor	33.51
DS18B20 Composite temperature sensor	1.29
Capacitive moisture sensor	1.03
HD38 Resistive moisture sensor	7.09
SGP30 Air quality sensor	11.86
CCS811 Air quality sensor	34.89
BH1750 Light sensor	1.37
LM2596 DC-to-DC converter	0.89
4-channel AC dimmer module	29.06
4-channel relay module	2.45
Solid state relay (SSR)	2.76
AMS1117 3.3 V voltage regulator module	0.49
AC-DC voltage adaptor	4.28
Plastic container	0.4

moisture sensor, BH1750 ambient light sensor, and the SGP30 CO<sub>2</sub> sensor. The ESP32 WROOM 32D has more GPIOs than the ESP8266 development board, especially analogue inputs. Furthermore, this development board contains GPIOs pins for I2C protocol that deal with the I2C sensors easily, such as the ambient light sensor BH1750. The CO<sub>2</sub> sensor, SGP30, has a moderate accuracy of about 15 %, but it is acceptable as an indicator of CO<sub>2</sub> level for the mushroom farm. Fig. 4 shows the detailed schematic diagram of this sensing node, where a DC-to-DC converter (LM2596) has also been used to provide more accurate supply voltage values for the sensors.

Finally, the highest-cost sensing node shown in Fig. 5 consists of ESP WROOM 32 as a development board, voltage regulator, SHT20 as a trustworthy temperature/humidity sensor that uses I2C protocol, DS18B20, HD-38 resistive soil moisture, and CCS811 for estimating CO<sub>2</sub> (eCO<sub>2</sub>) and Total Volatile Organic Compounds (tVOC). The SHT20 has high quality and it is water-proof and works on I2C protocol. The CO<sub>2</sub> sensor CCS811 is also of high quality and works on I2C protocol. The schematic diagram of the highest-cost sensing node with detailed pin numbers is shown in Fig. 5.

The previous three varieties for sensing nodes were designed and



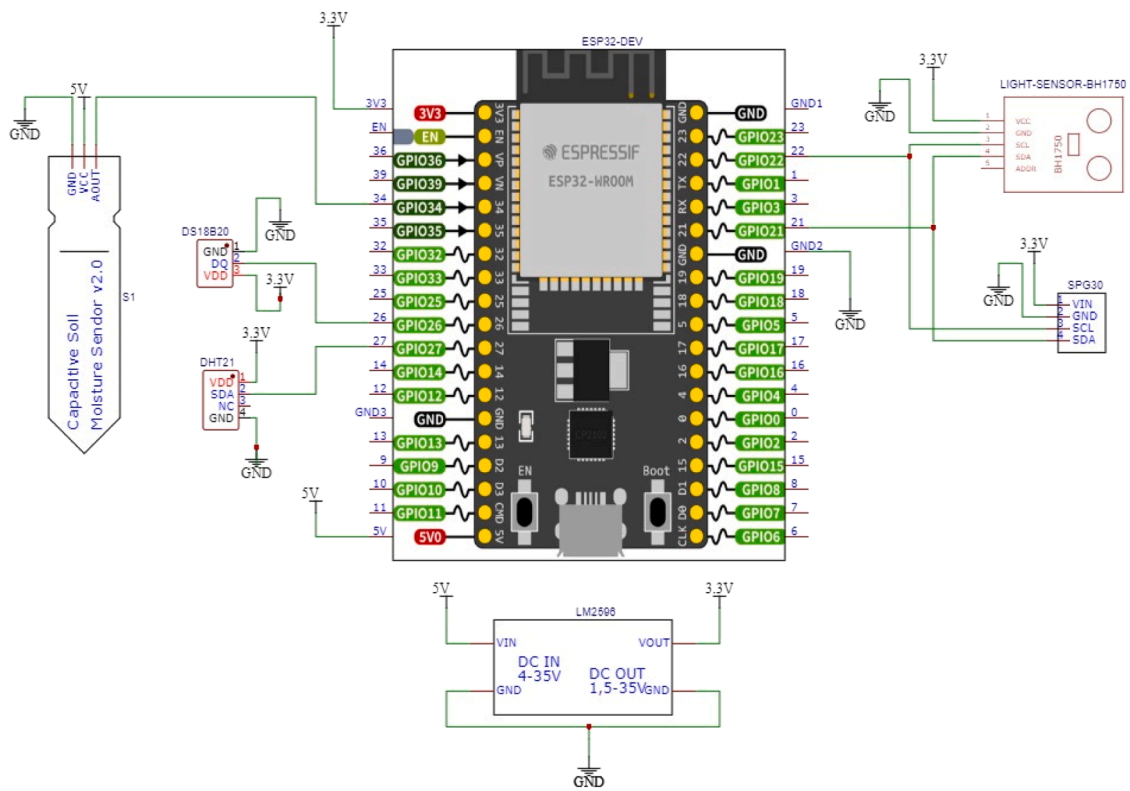

Fig. 4. Medium-cost sensing node.

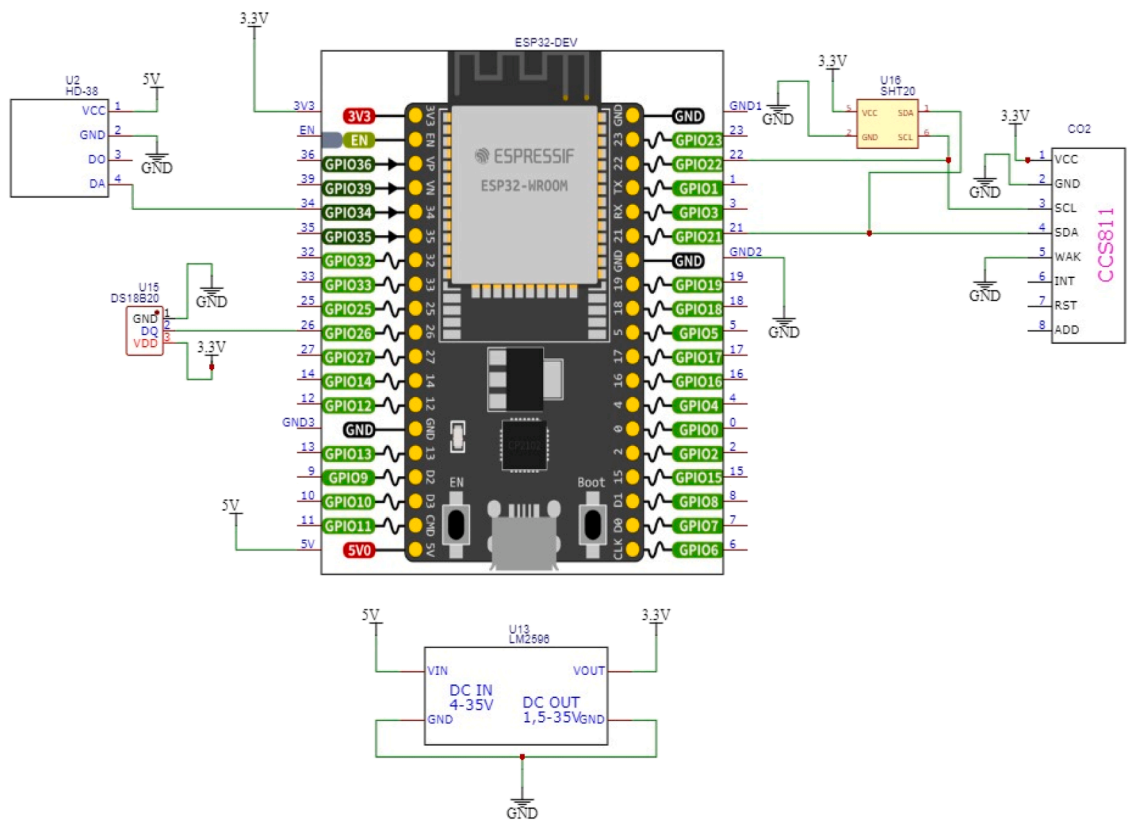

Fig. 5. Highest-cost sensing node.

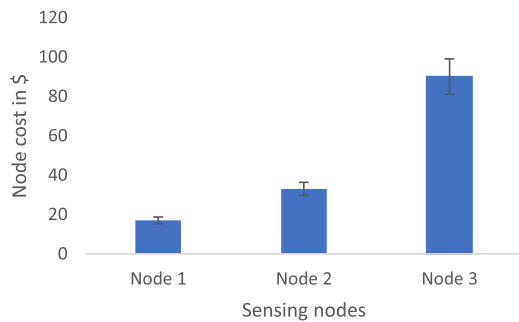

Fig. 6. Costs of sensing nodes.

implemented to offer different choices for mushroom farmers of different scales starting from very small-scale refugee farmers up to medium- and high-scale farmers. Lowest, medium and highest-cost sensing nodes cost about \$17, \$33 and \$90, respectively (Fig. 6), according to 2023 prices in Turkey where the experiments were conducted. All provided costs include also the cost of a voltage adaptor for every node.

## 2.2. Control nodes

For the control and management section of the farm, two different control nodes were designed and implemented, and a ThingSpeak channel was assigned for every control node. Fig. 7 shows the basic control node, which meets the minimum needs of a simple mushroom farm at an affordable price. Fig. 8 shows the more advanced one for a mushroom farm with high specifications that can control up to seven DC and AC devices.

Starting with the first basic control circuit, which controls three devices necessary for a mushroom farm: a humidifier, an air circulation fan, and an extractor fan. As shown in Fig. 7, an ESP8266 microcontroller, a 4-channel relay module and voltage regulators were utilized.

The advanced control node can control more devices that could exist in a larger mushroom farm, which includes: an air conditioner, a humidifier, lights, two air circulation fans, and two extractor fans as shown in Fig. 8. The most reliable electric control elements for the air conditioner, humidifier, and light are solid-state relays (SSRs) because they provide complete isolation between the output of the microcontroller and the input of the high-current/voltage devices. For the four air fans, the solid-state relays can also be used, but to control the speed of the fans a 4-channel alternating current (AC) dimmer module was added to respond better to the operation of other devices, such as air conditioner and humidifier. Five different speeds, in addition to the Off state, were supported as follows: 0, 20, 40, 60, 80, and 100 % of the maximum speed for each fan.

Finally, a cost comparison was made between the basic control node (about \$14) and the advanced control node (about \$49) as illustrated in Fig. 9. With simple technical help, the farmers can choose the most suitable nodes to implement in their farms with costs starting from about \$30 for the two simplest sensing and control nodes. Also, it is worth mentioning that suitable packaging for the nodes is necessary to prevent high humidity from adversely affecting the boards. This can be done simply using affordable plastic food storage containers with secure closures.

## 2.3. Application user interface

Every sensing or control node has been associated with a ThingSpeak channel for saving the node data. For control nodes, a web page that can be accessed using any smartphone, tablet, or any personal computer, was developed to allow farmers to control the mushroom farm devices in a convenient way. Additionally, a MATLAB application was also developed for controlling farm devices for professional users. The user

interface is simple and user-friendly, where the farmer can select any device to turn it On or Off with simple indicators and history of the control commands for the MATLAB application. Fig. 10 shows the web page (a) and MATLAB application (b) of the basic control node. Two successive control commands should be separated by at least 15 s to ensure proper update and operation of the ThingSpeak channel. The user interfaces can also be integrated with ThingSpeak to save and monitor current and historical data related to the state of the controlled device.

The same is true for the advanced control circuit that also has user interfaces as a web page and a MATLAB application, as shown in Fig. 11 (a) and (b), respectively.

Fig. 12 illustrates that the MATLAB application also support reading the data of the sensing nodes, Fig. 12(a), and controlling the devices using the control node. It can read the current status of all connected devices to the control node, such as air conditioner, humidifier, luminance, the two air circulation fans, and the two extractor fans, Fig. 12 (b). It has been taken into account that the control panel is as simple as possible and contains all the necessary tabs in order to control all devices in the mushroom farm, in addition to monitoring sensor data.

## 2.4. Cloud and IoT platform

The last part of our proposed system is the utilized cloud or IoT platform. Many IoT platforms have been trialled to adopt ThingSpeak, Fig. 13, as an IoT platform to aggregate, visualize and analyse live data streams in the cloud. The main advantage of the usage of the ThingSpeak platform is providing instant visualizations of data posted by sensors and devices in addition to historical data storage. Additionally, ThingSpeak supports all analysis and visualization capabilities of MATLAB, and it can be integrated with other websites easily. For example, a dedicated website was designed to provide a user interface for farmers to read the sensor values and control the devices on the farm. The farmer can access the farm dashboard through ThingSpeak directly or through a registered account on the website, connected with ThingSpeak, using a username and password to assure privacy and guarantee security. Fig. 14 shows the farm dashboard accessed remotely and securely. Also, the website interfaces have been designed to support different devices such as smartphones, tablets and personal computers.

## 3. Results analysis and discussion

Sensor data in addition to camera images were collected and saved successfully. Data related to relative humidity, temperature, the composite temperature inside the mushroom bag, moisture inside the bag and CO<sub>2</sub> were collected successfully for two cultivation cycles. In the second cycle, the number of parameters were increased and most of the technical issues faced in the first cycle were overcome. More than 66,000 one-minute measurements were collected and saved for the second cycle. For both cycles, the number exceeds 3,90,000 for 20-second measurements. Furthermore, a data set containing more than 700 farm images and 500 videos, was also built successfully.

Fig. 15 shows the Arduino IoT platform with the instant values of four monitored variables: temperature, relative humidity, temperature inside bag, and moisture, with only one-day data storage and visualization in the first agricultural cycle. Arduino IoT platform supports different computing devices from PCs, tablets and smartphones, but for free accounts only two things/nodes with a maximum of four variables for each can be connected and one-day data storage and visualization are available. On the other hand, a ThingSpeak free account supports four channels/nodes with much more storage, analysis and visualization capabilities. Each channel supports up to eight different fields/variables of data. Fig. 16 shows two fields of a ThingSpeak channel that show the instant and hourly monitored temperature and relative humidity values of an SHT20 sensor connected to a sensing node, which is associated with this channel and reads sensor values every minute. The hourly graphs clearly illustrate fluctuations of the sensor values due to the

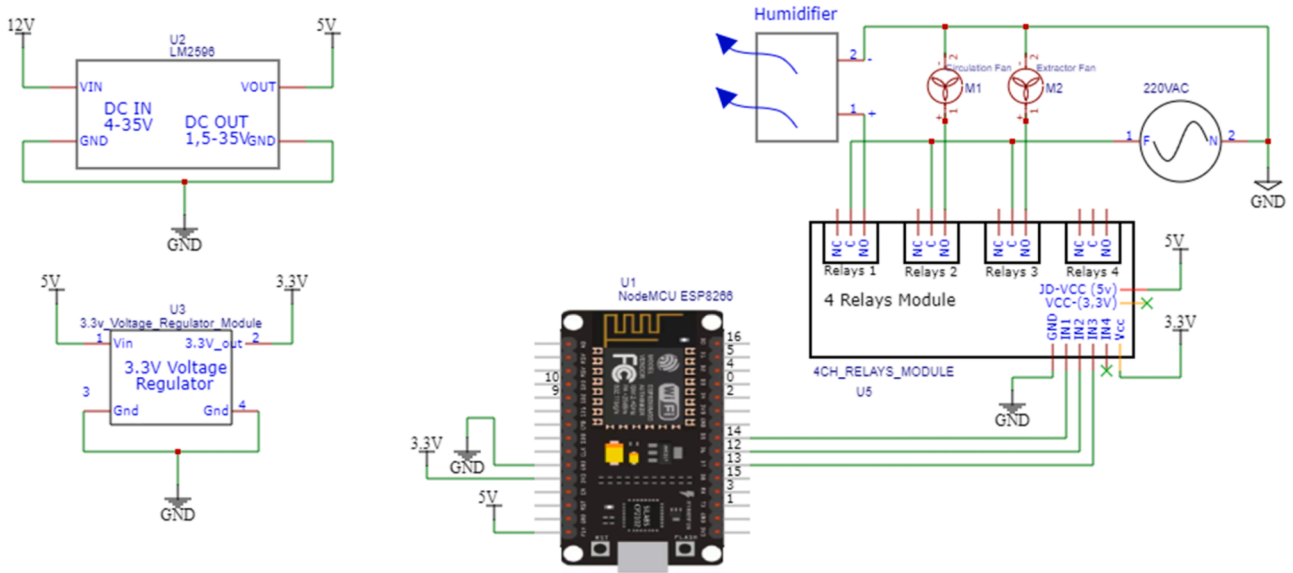

Fig. 7. Basic control node.

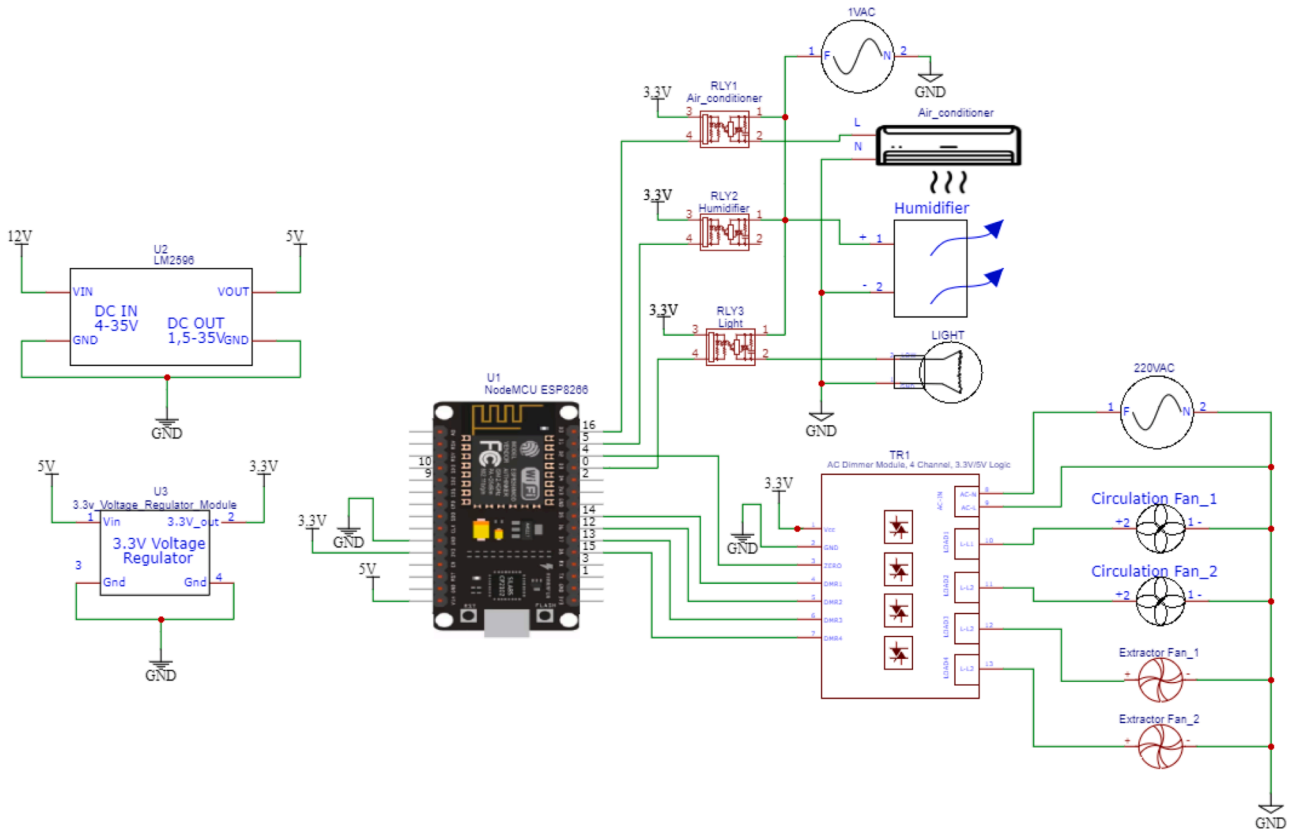

Fig. 8. Advanced control node.

working pattern of the extractor fans, which were adjusted by the farmer to work when the temperature exceeds 19 °Celsius and stop when under 19 °C to keep the farm temperature around 19 °C.

Similar fluctuations caused by the working pattern of the extractor fans can also be seen for the CSS811 air-quality sensor, which measures estimated CO<sub>2</sub>, eCO<sub>2</sub>, and tVOC as shown in Fig. 17.

The lower-cost DHT21 sensor (Fig. 18), showed similar fluctuations with temperature values (18.5 °C - 18.7 °C) and relative humidity values (75.2 % - 76.7 %) compared to the temperature values (18.8 °C - 19.05 °C)

and relative humidity values (69.2 % - 70.7 %) of the higher-cost dependable SHT20 sensor. Larger differences in relative humidity values between the two sensors were observed with higher humidity values.

Regarding the lower-cost air-quality SGP30 sensor, Fig. 19, similar fluctuations due to the working style of extractor fans were also noted but with higher differences in values when compared to the higher-cost CSS811 sensor.

Furthermore, ThingSpeak offers more powerful data analysis tools, as MATLAB scripts, visualizations, and applications are supported by

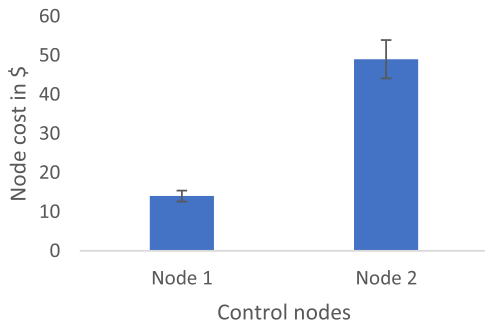

Fig. 9. Control nodes costs.

ThingSpeak platform. Fig. 20 shows daily and weekly data visualizations, where the differences between day and night, especially for relative humidity values, are very clear. These differences are related to working style of the extractor fans at this period, where they were working on timer in day and constantly in night to keep the temperature of the farm around 19°.

Temperature data from different sensing nodes were also compared in Fig. 21 in the farm and inside mushroom bags. The temperature values inside mushroom bags were substantially higher in one bag due to mycelium colonization inside that bag. The working pattern of the circulation fans was changed by the farmer on 20 March afternoon (13:00 local time), which was reflected in the temperature values depending on their distance from the fans. Also, temperatures spiked on 20 March morning due to a power cut (07:53–08:43 local time), which caused an increase in temperature values of about two degrees. Then, temperatures were restored in less than ten minutes when the power came back and the fans began working again.

Power cuts were occasionally experienced, usually lasting no more than an hour. However, there was a prolonged internet outage due to a

technical issue with the service provider. In response, a mobile internet connection was used to restore the required internet service for remote monitoring and management of the farm. Of course, it is essential to take precautions and have alternatives in place to overcome such unexpected outage problems. Various types of mobile power generators and internet connections can be utilized for such situations.

Fig. 22(a) shows comparisons of relative humidity for three different sensing nodes. The differences between day and night were clear and a prominent spike value in humidity was also seen due to the farmer’s intervention by launching the humidifier manually for ten minutes. Fig. 22(b) shows eCO<sub>2</sub> values measured by SGP30 and CSS811 sensors, where the differences between the sensor values were large, but generally, they behaved in a similar way such that any of them can be utilized as an affordable indicator for the CO<sub>2</sub> level in the farm.

Fig. 23 shows images from the farm in two different cultivation cycles, where the extractor and circulation fans can be seen in the background. These images were captured by the cameras inside the farm. Furthermore, a dataset of mushroom images has been built for using in further work using CV, AI and ML applications.

Another noticeable result was that the farmer who was enforced to commute to the farm twice a day to check the mushrooms, was able to monitor and manage the farm remotely when using the proposed system, reducing fuel and time costs.

Ultimately, the technical design and implementation files, source codes, and instruction manual of all varieties of sensing and control nodes of the proposed oyster mushroom cultivation system will be made available under the CC BY license. Thus, the system can be configured and reproduced not only by NGOs and authorities working for refugee and displaced communities but also by any group that chooses to implement it. The system was implemented for oyster (*Pleurotus ostreatus*) mushroom cultivation in a greenhouse environment with temperature values ranging from 5 °C to 25 °C and relative humidity values at 60–95 %. However, the system can be adapted for different mushroom types, as well as for other crops, which are cultivated in

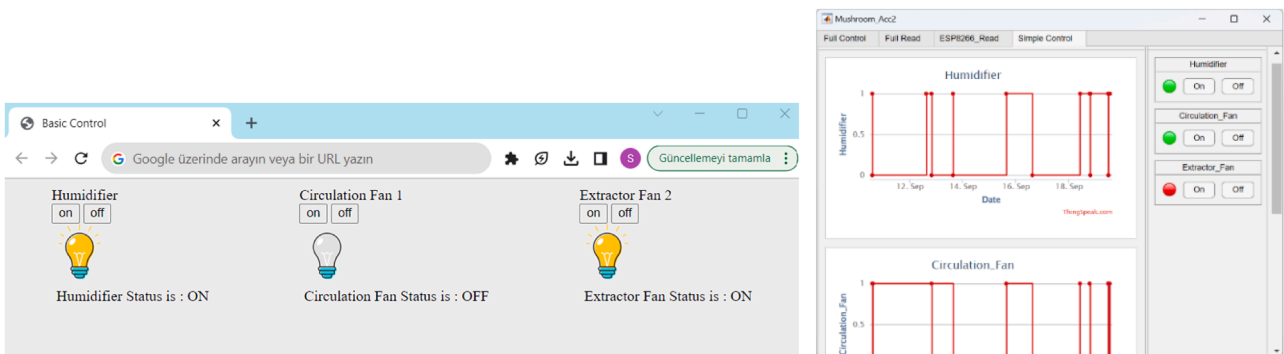

Fig. 10. Basic control node user interfaces (a) Web page (b) MATLAB application.

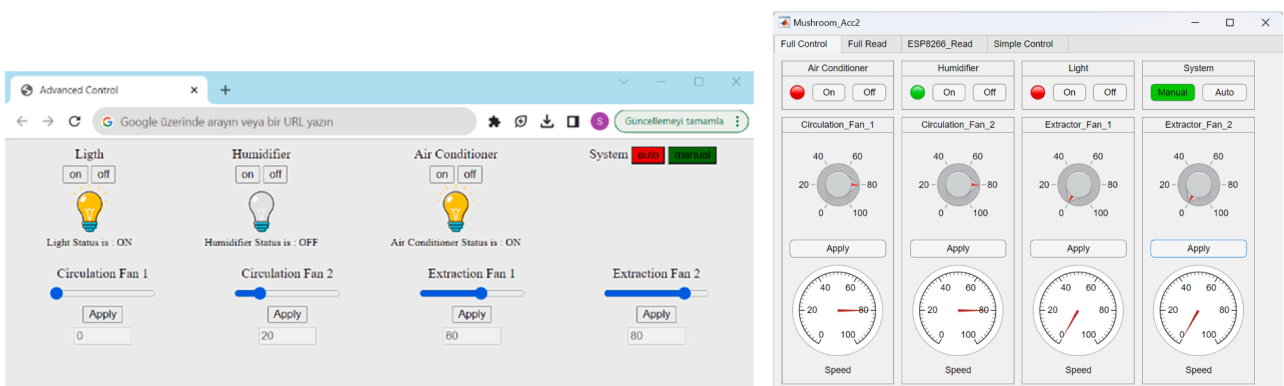

Fig. 11. Advanced control node user interfaces (a) Web page (b) MATLAB application.



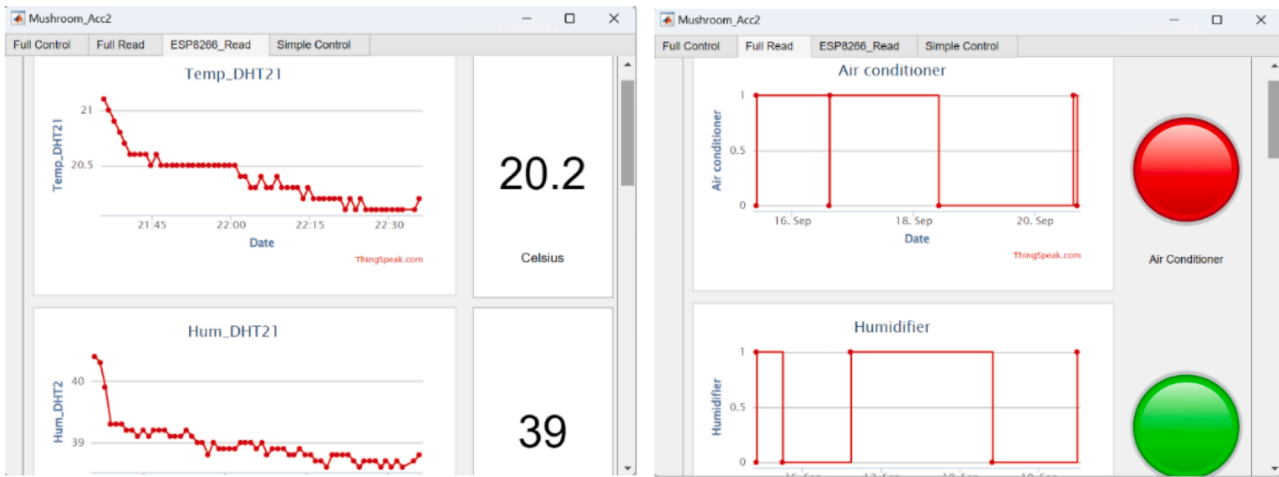

Fig. 12. MATLAB application user interfaces (a) sensor data reading (b) control data reading.

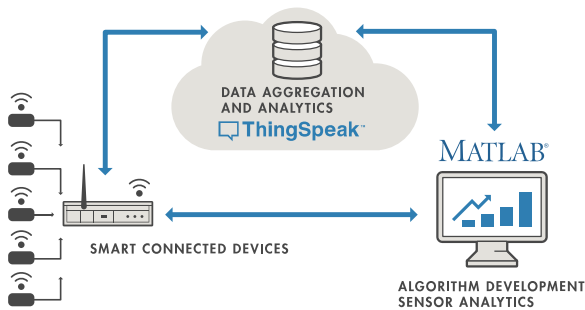

Fig. 13. ThingSpeak IoT platform.

greenhouse farming systems by configuring it to operate under the desired values of temperature and relative humidity at different cultivation phases depending on the species [3,13]. For example, the number of sensing nodes can be increased according to the size of the farm/-greenhouse, and the sensors themselves can be replaced with more appropriate sensors for the cultivated mushroom or crop. The same can

also be said for control nodes, where various farm necessary devices can be controlled and managed by these nodes using the same architecture and user interfaces.

#### 4. Conclusion

This research clearly shows that it is possible to design and implement an efficient and affordable remote monitoring and controlling system for organic oyster mushroom farming with costs starting from about \$30. The deployment of this system drew promising insights represented by reducing labour efforts and production costs in addition to increasing the crop production time thanks to the remotely controlled and monitored process. This simplifies the mushroom cultivation process so that it can be operated by lay people with a modest amount of training, especially for internally displaced and refugee Syrians. Furthermore, it can support them with an extra income and an additional source of good nutrition.

The implemented varieties of the oyster mushroom cultivation system in this study can be adapted for other mushroom types as well as for crops cultivated in greenhouse farming systems, as most of such systems

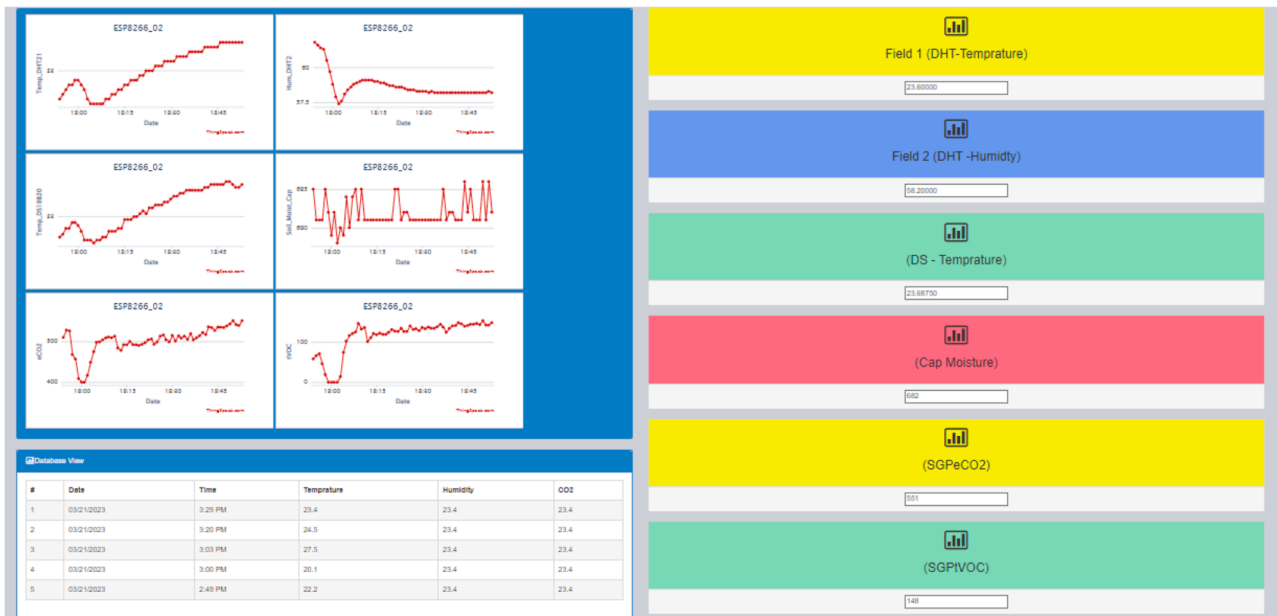

Fig. 14. Website interface with farmer dashboard.



Fig. 15. Arduino IoT platform interface (23 Jan 2023).

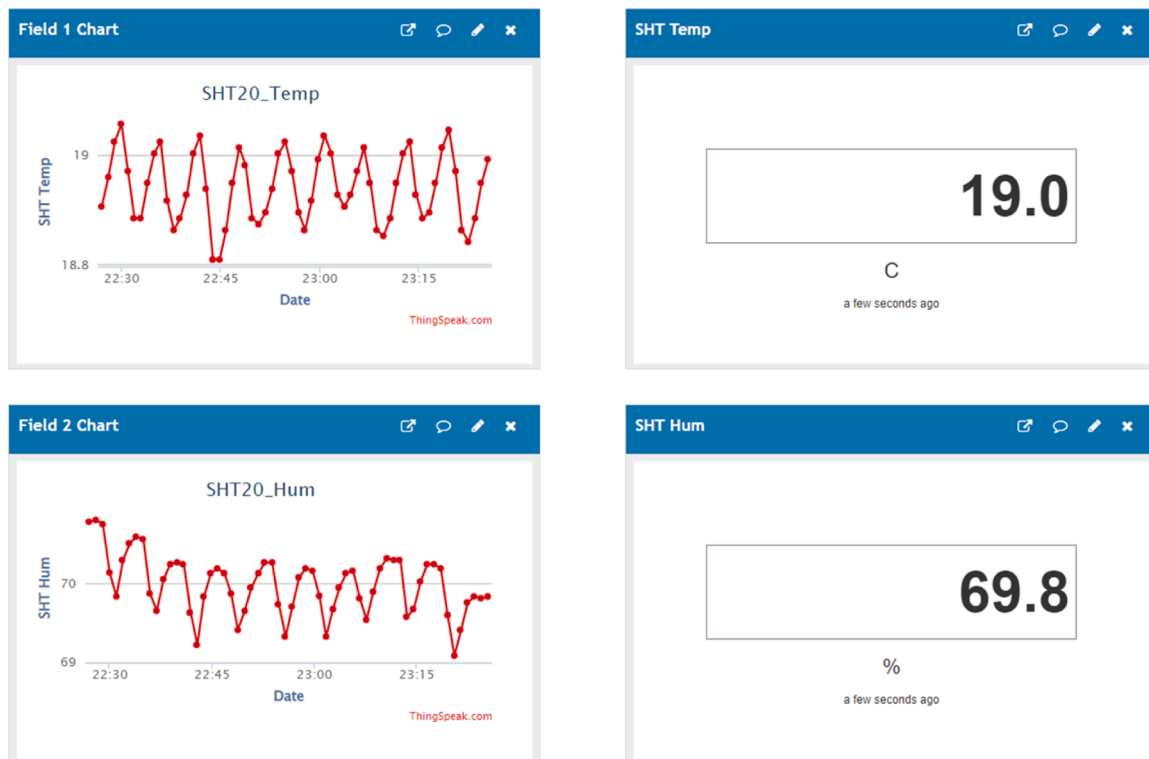

Fig. 16. ThingSpeak IoT platform interface of SHT sensor (25 Mar 2023).

rely on monitoring the greenhouse environment and managing the various relevant devices for controlling the internal greenhouse conditions.

The project outputs can be shared not only with NGOs and authorities working on agriculture projects for internally displaced and refugee

Syrians, but also with other agriculturalists in low-income countries for example. The operation and use of the system can be incorporated into mushroom cultivation training courses and workshops offered by these stakeholders. The proposed system can be produced on a larger scale for organizations working for refugees, where some UN agencies and

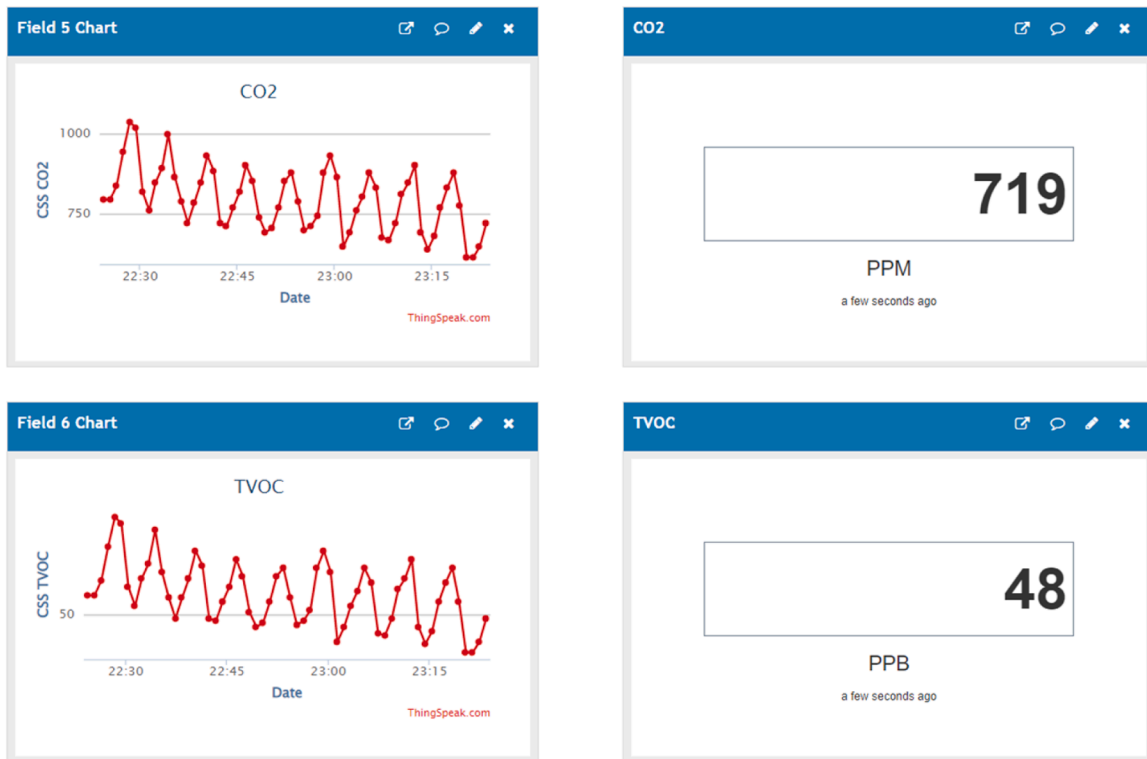

Fig. 17. ThingSpeak IoT platform interface of CSS sensor (25 Mar 2023).



Fig. 18. ThingSpeak IoT platform interface of DHT21 sensor (25 Mar 2023).

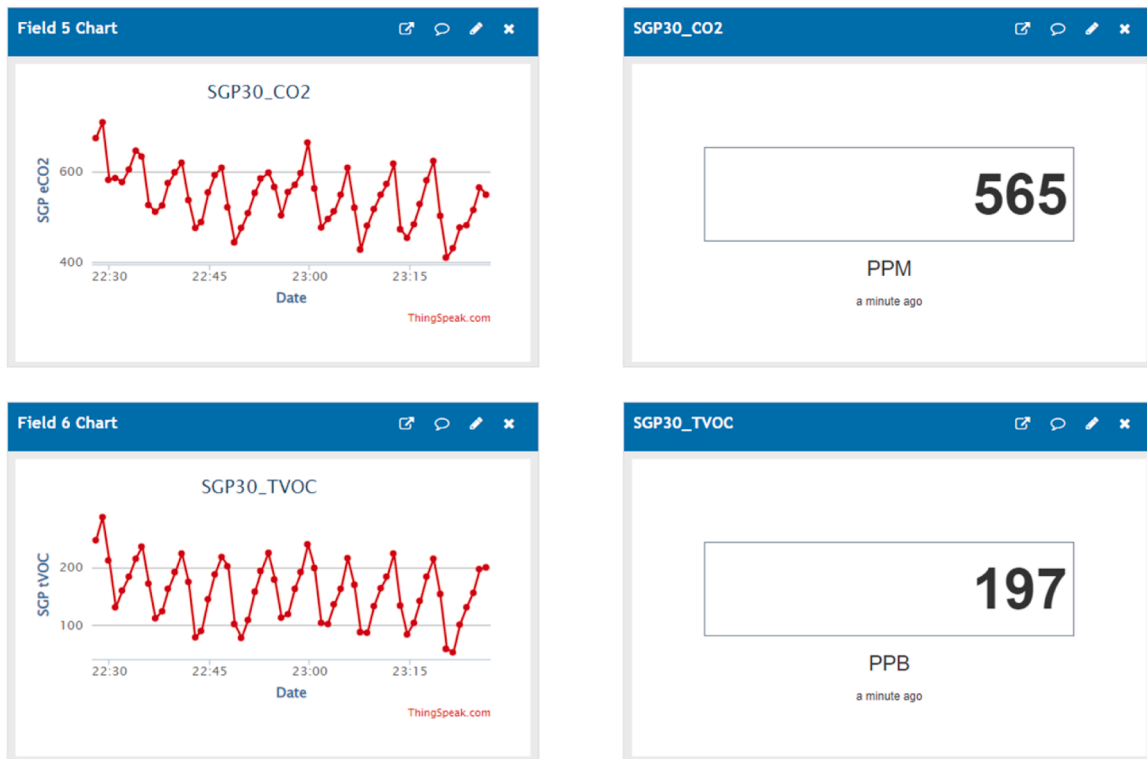

Fig. 19. ThingSpeak IoT platform interface of SGP30 sensor (25 Mar 2023).

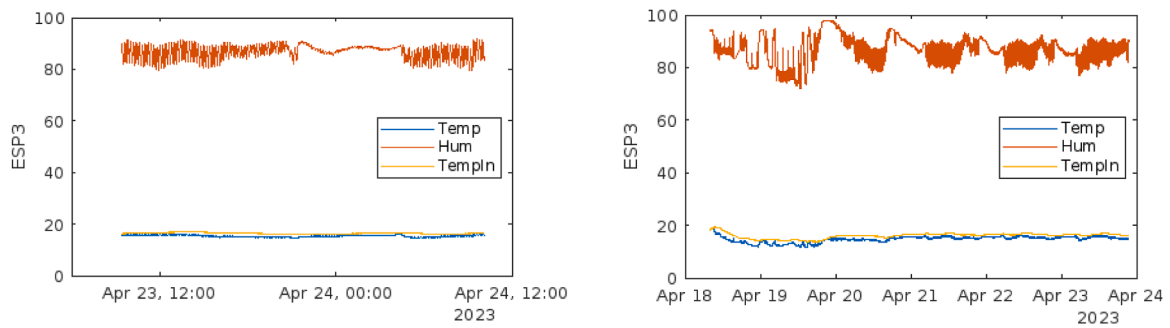

Fig. 20. Data graphs showing temperature and relative humidity (a) daily and (b) weekly values.

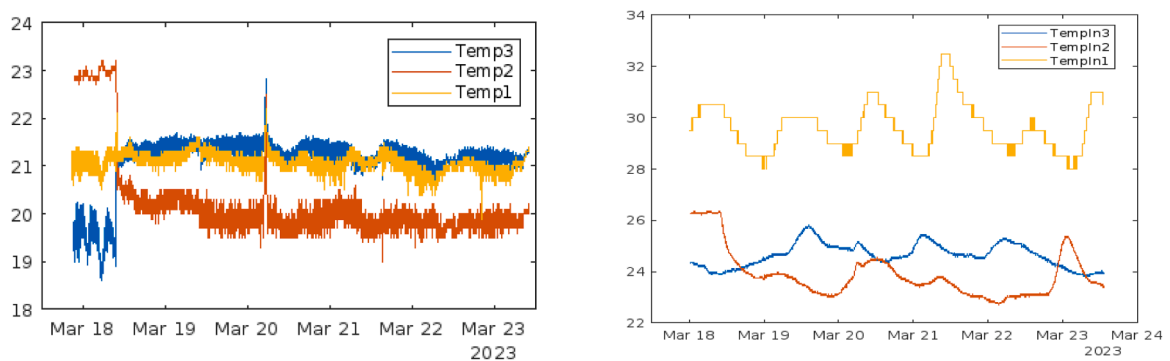

Fig. 21. Data graphs showing comparisons of temperature values (a) in farm and (b) inside bags.



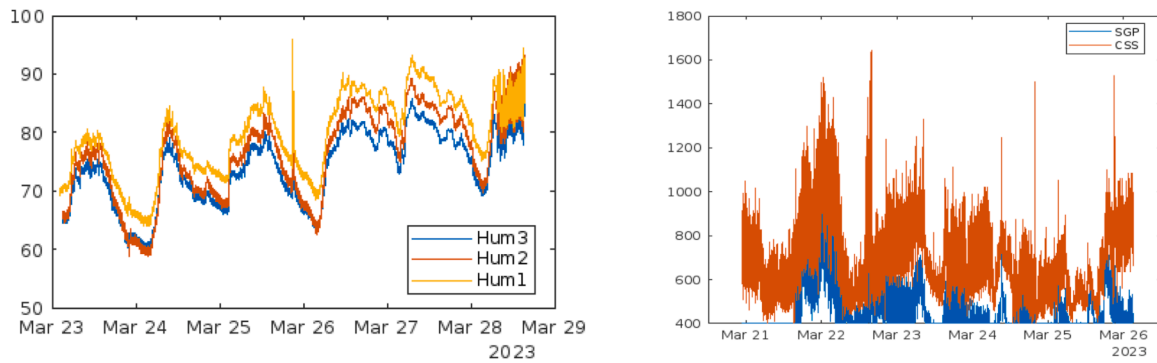

Fig. 22. Data graphs showing comparisons of (a) relative humidity and (b) air quality data.



Fig. 23. Images from the farm.

international or local NGOs support such activities as a part of livelihood and local economic recovery programs.

#### Ethics statement

Not applicable: This manuscript does not include human or animal research.

#### Funding

This work was supported by the Council for At-Risk Academics (Cara) [Apr22URN15 grant].

#### CRediT authorship contribution statement

**Abdullah Elewi:** Writing – original draft, Validation, Resources, Project administration, Methodology, Conceptualization. **Abdulsalam Hajhamed:** Writing – original draft, Validation, Resources, Conceptualization. **Rasheed Khankan:** Writing – original draft, Software, Investigation. **Sonay Duman:** Software, Data curation. **Amina Souag:** Writing – review & editing, Validation, Supervision. **Asma Ahmed:** Writing – review & editing, Supervision, Conceptualization.

#### Declaration of competing interest

The authors declare that they have no known competing financial interests or personal relationships that could have appeared to influence the work reported in this paper.

#### Data availability

No datasets were analysed in this work. Source code files and an instructional document are provided as supplementary material.

#### Acknowledgement

The authors would also like to thank Dr. Denise De Pauw from

University of Leeds for providing language support during the writing of this paper.

#### Supplementary materials

Supplementary material associated with this article can be found, in the online version, at [doi:10.1016/j.atech.2024.100439](https://doi.org/10.1016/j.atech.2024.100439).

#### References

- [1] R. Abbasi, P. Martinez, R. Ahmad, The Digitization of Agricultural Industry – a Systematic Literature Review On Agriculture 4.0. *Smart Agricultural Technology*, Elsevier B.V., 2022, <https://doi.org/10.1016/j.atech.2022.100042>.
- [2] P.K. Angral, R. Thakur, Different automatic monitoring and controlling technique for mushrooms, *Turk. J. Comput. Math. Educ.* 12 (11) (2021) 3363–3369.
- [3] M.B. Bellettini, F.A. Fiorda, H.A. Maievas, G.L. Teixeira, S. Ávila, P.S. Hornung, R. H. Ribani, Factors affecting mushroom *Pleurotus* spp, *Saudi. J. Biol. Sci.* 26 (4) (2019) 633–646, <https://doi.org/10.1016/j.sjbs.2016.12.005>.
- [4] L. He, L. Fu, W. Fang, X. Sun, R. Suo, G. Li, R. Li, IoT-based urban agriculture container farm design and implementation for localized produce supply, *Comput. Electron. Agric.* 203 (2022), <https://doi.org/10.1016/j.compag.2022.107445>.
- [5] International Agricultural Cooperation Organization I.A.C.O. (2020), Manual of agricultural mushroom production in Syria, <http://iaico-sy.org/?p=988>.
- [6] Y. Jararweh, S. Fatima, M. Jarrah, S. AlZu'bi, Smart and sustainable agriculture: fundamentals, enabling technologies, and future directions, *Comput. Electr. Eng.* 110 (2023), <https://doi.org/10.1016/j.compeleceng.2023.108799>.
- [7] E.M.B.M. Karunathilake, A.T. Le, S. Heo, Y.S. Chung, S. Mansoor, The path to smart farming: innovations and opportunities in precision agriculture, *Agriculture* 13 (2023) 1593, <https://doi.org/10.3390/agriculture13081593>, 2023.
- [8] M.R.M. Kassim, I. Mat, I.M. Yusoff, Applications of internet of things in mushroom farm management, in: *Proceedings of the International Conference on Sensing Technology, ICST 2019-December*, IEEE Computer Society, 2019, <https://doi.org/10.1109/ICST46873.2019.9047702>.
- [9] C.P. Lu, J.J. Liaw, A novel image measurement algorithm for common mushroom caps based on convolutional neural network, *Comput. Electron. Agric.* 171 (2020), <https://doi.org/10.1016/j.compag.2020.105336>.
- [10] M.S.A. Mahmud, S. Buyamin, M.M. Mokji, M.S.Z. Abidin, Internet of things based smart environmental monitoring for mushroom cultivation, *Indones. J. Electr. Eng. Comput. Sci.* 10 (3) (2018) 847–852, <https://doi.org/10.11591/ijeecs.v10.i3.pp847-852>.
- [11] M.F. Mohammed, A. Azmi, Z. Zakaria, M.F.N. Tajuddin, Z.M. Isa, S.A. Azmi, IoT based monitoring and environment control system for indoor cultivation of oyster mushroom, in: *Proceedings of the Journal of Physics: Conference Series* 1019, Institute of Physics Publishing, 2018, <https://doi.org/10.1088/1742-6596/1019/1/012053>.
- [12] H. Rahman, M.O. Faruq, T.B. Abdul Hai, W. Rahman, M.M. Hossain, M. Hasan, M. M Azad, IoT enabled mushroom farm automation with Machine Learning to

- classify toxic mushrooms in Bangladesh, *J. Agric. Food Res.* 7 (2022), <https://doi.org/10.1016/j.jafr.2021.100267>.
- [13] J. Raman, K.Y. Jang, Y.L. Oh, M. Oh, J.H. Im, H. Lakshmanan, V. Sabaratnam, Cultivation and nutritional value of prominent pleurotus Spp.: an overview, *Mycobiology* 49 (1) (2021) 1–14, <https://doi.org/10.1080/12298093.2020.1835142>.
- [14] A. Subedi, A. Luitel, M. Baskota, T.D. Acharya, IoT Based Monitoring System for White Button Mushroom Farming, MDPI AG, 2020, p. 46, <https://doi.org/10.3390/ecsa-6-06545>.
- [15] Y.D. Surige, W.S.M. Perera, P.K.N. Gunarathna, K.P.W. Ariyaratna, N. Gamage, D. Nawinna, IoT-based monitoring system for oyster mushroom farming, in: Proceedings of the ICAC 2021 - 3rd International Conference on Advancements in Computing, Proceedings, 2021, pp. 79–84, <https://doi.org/10.1109/ICAC54203.2021.9671112>.
- [16] S.T. Ten, G. Krishnen, K.A. Khulidin, M.A. Mohamad Tahir, M.H. Hashim, S. Khairudin, Automated controlled environment mushroom house, *Adv. Agric. Food Res. J.* (2021), <https://doi.org/10.36877/aafri.a0000230>.
- [17] N. Thong-un, W. Wongsaroj, Productivity enhancement using low-cost smart wireless programmable logic controllers: a case study of an oyster mushroom farm, *Comput. Electron. Agric.* 195 (2022), <https://doi.org/10.1016/j.compag.2022.106798>.
- [18] P. Tongcham, P. Supa, P. Pornwongthong, P. Prasitmeeboon, Mushroom spawn quality classification with machine learning, *Comput. Electron. Agric.* 179 (2020), <https://doi.org/10.1016/j.compag.2020.105865>.
- [19] UN Data, A world of information (2020). <http://data.un.org/Data.aspx?d=FAO&f=itemCode%3A449>.
- [20] H. Yin, W. Yi, D. Hu, Computer vision and machine learning applied in the mushroom industry: a critical review, *Comput. Electron. Agric.* (2022), <https://doi.org/10.1016/j.compag.2022.107015>.
- [21] A. Walter, R. Finger, R. Huber, N. Buchmann, Opinion: smart farming is key to developing sustainable agriculture, *Proc. Natl. Acad. Sci. U. S. A.* 114 (2017) 6148–6150, <https://doi.org/10.1073/pnas.1707462114>, 2017.
- [22] M. Zhu, J. Shang, Remote monitoring and management system of intelligent agriculture under the internet of things and deep learning, *Wirel. Commun. Mob. Comput.* 2022 (2022), <https://doi.org/10.1155/2022/1206677>.