

2nd International  
Forum on

# Neural Engineering & Brain Technologies

20-21.06.2023

Berlin, Germany

# CATALOGUE

# NEURAL SIGNALS INTERFACES FORUM 2024

## Repair. Restore. Augment.

### Neural Signals

- Invasive & non-invasive measurements of brain signals
- Novel signal/image acquisition, sensing & processing techniques
- Multi-modality, multivariate statistical signal processing
- EEG acquisition & data analysis
- Signal processing in brain-computer interface & neuro-prosthetic devices
- AI analysis of big neuroscience datasets
- Artificial Intelligence & advanced signal processing for neurological disorders
- New trends & techniques in intelligent signal processing & data analysis

AI\_Driven\_Neuro

AI

in Signal &  
Data Processing

### Neural Interfaces

- Bioelectronic interfaces, neural electronics
- Neural recording & stimulation
- Implantable, non-invasive, hybrid techniques
- Biocompatible designs, biomaterials development, device fabrication
- Microelectrode array technology, novel electrodes
- Brain computer/machine interfaces
- Neural control of prosthetics

11-12 June 2024. Berlin, Germany

[www.nbt-berlin.de](http://www.nbt-berlin.de) #nbtberlin

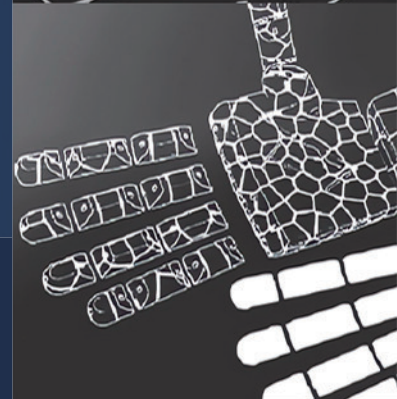
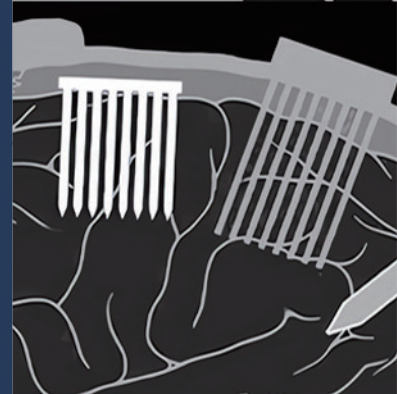
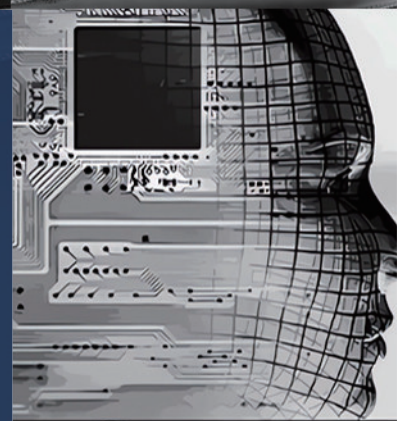

NBT BERLIN - 3RD INTERNATIONAL FORUM ON NEURAL ENGINEERING & BRAIN TECHNOLOGIES

Organized by DEMACH Event- und Veranstaltungs GmbH. Berlin, Germany. [www.demach-events.de](http://www.demach-events.de)

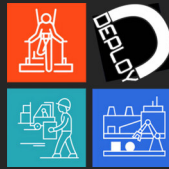

# EXO BERLIN

## 4th International Exhibition & Conference on Human-Augmentation Robots



### ASSISTIVE ROBOTICS

- Exoskeletons, exosuits
- Intelligent assist devices
- Supernumerary robotic limbs
- Wearable sensors
- Biofeedback devices
- Smart fabrics
- Novel actuators, sensors, & mechanism, functional components
- Interaction & control of assistive robotic devices
- Human performance monitoring, motion analysis



### COLLABORATIVE ROBOTS

- Healthcare collaborative robots
- Industrial collaborative robots
- Soft robotics
- Strategies for Human-Robot collaboration
- Rapidly integrable solutions
- Evaluate, deploy, manage, & monitor robots in various applications

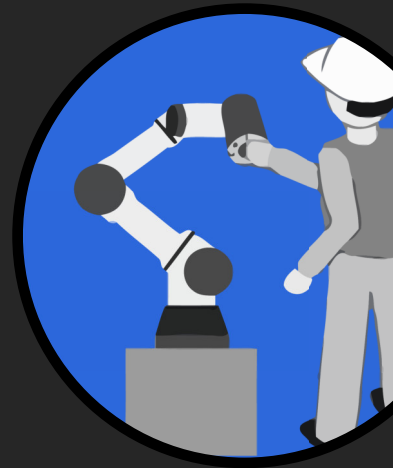

Co-located with  
**DEPLOYMENT FORUM 2023**

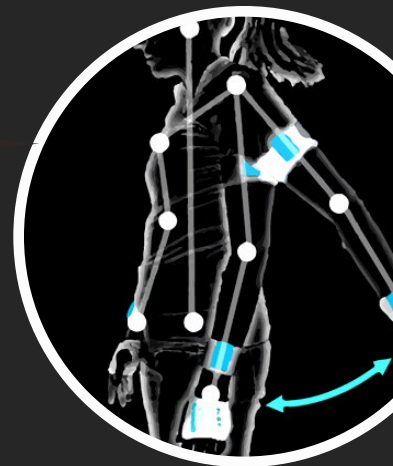

**24-25 October 2023. Berlin, Germany**

[www.exo-berlin.de](http://www.exo-berlin.de) #exoberlin

# COUNTRIES OF ATTENDEES

NBT Berlin 20.-21.06.2023

Last updated on 16:00 CET, 16 June 2023

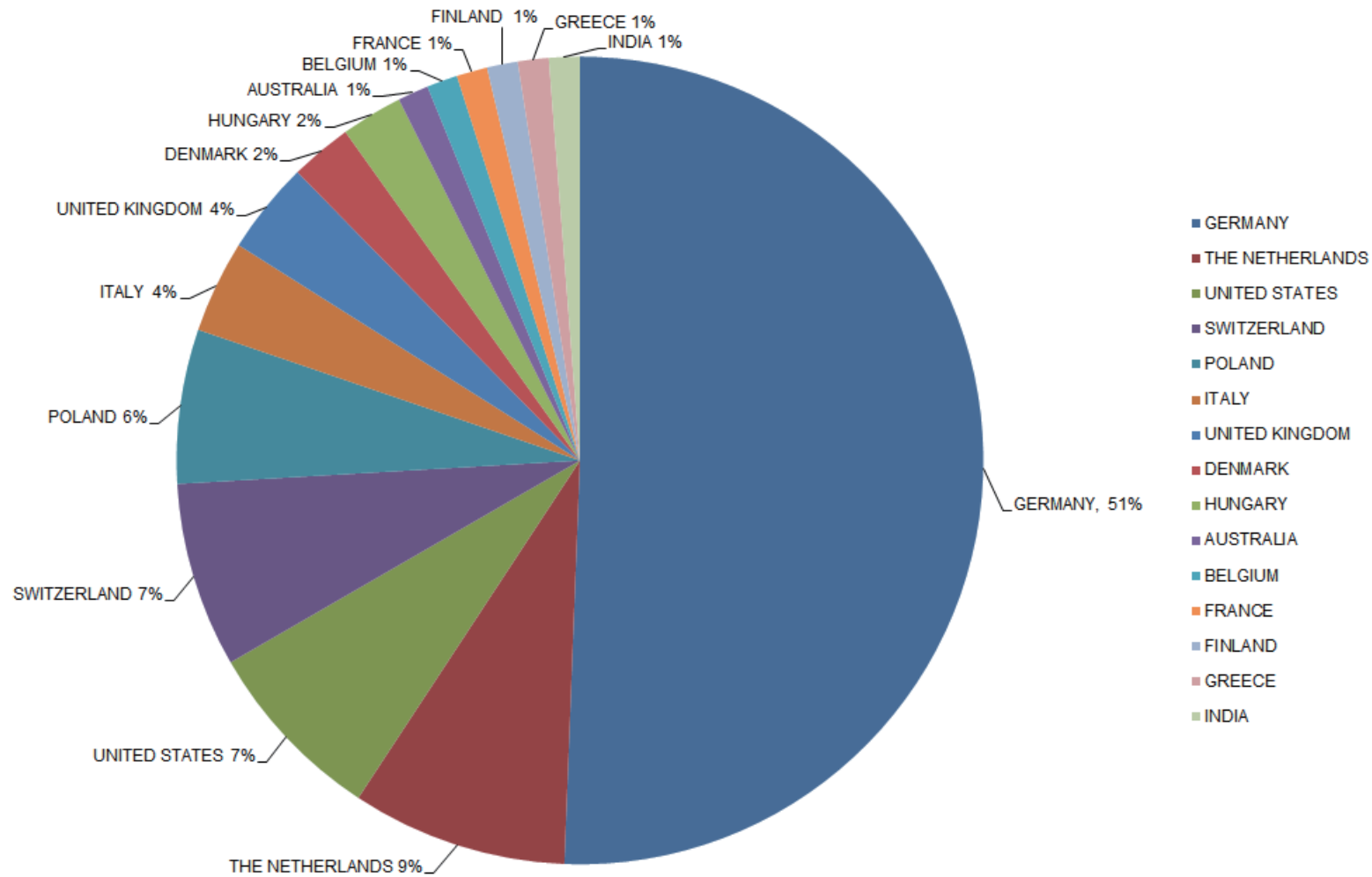

# INDEX

## SPEAKER

- CANTERBURY CHRIST CHURCH UNIVERSITY / UNITED KINGDOM
- CHARITE UNIVERSITÄTSMEDIZIN BERLIN / GERMANY
- FED RES CTR FUNDAMENTAL & TRANSLAT MED / GERMANY
- FORSCHUNGSZENTRUM INFORMATIK (FZI) / GERMANY
- FORSCHUNGSZENTRUM JÜLICH / GERMANY
- FRAUNHOFER INSTITUTE FOR RELIABILITY AND MICROINTEGRATION IZM, BERLIN, GERMANY  
DELFT UNIVERSITY OF TECHNOLOGY, THE NETHERLANDS. / GERMANY
- FRAUNHOFER INSTITUTE FOR TOXICOLOGY AND EXPERIMENTAL MEDICINE ITEM / GERMANY
- GDANSK UNIVERSITY OF TECHNOLOGY / POLAND
- HASSO PLATTNER INSTITUTE / GERMANY
- IDUN TECHNOLOGIES / SWITZERLAND
- INNER PSYCHOPHYSICS IP LLC / UNITED STATES
- MINDROVE KFT / HUNGARY
- NIRX MEDIZINTECHNIK GMBH / GERMANY
- POLITECNICO DI MILANO / ITALY
- QUANTUM BIOMETRONICS / GREECE
- TILBURG UNIVERSITY / THE NETHERLANDS
- TIMEFLUX / FRANCE
- UNIVERSITY OF CATANIA, CATANIA; OASI RESEARCH INSTITUTE-IRCCS, TROINA / ITALY
- UNIVERSITY OF TECHNOLOGY SYDNEY / AUSTRALIA
- UNIVERSITY OF WASHINGTON / UNITED STATES
- UNIVERSITY OF MANCHESTER / UNITED KINGDOM

## EXHIBITOR

- GDANSK UNIVERSITY OF TECHNOLOGY / LITHUANIA
- IDUN TECHNOLOGIES / SWITZERLAND
- INNER PSYCHOPHYSICS IP LLC / UNITED STATES
- METIS NEUROTEC, KARLSRUHE INSTITUTE OF TECHNOLOGY / UNITED STATES
- MINDROVE KFT / HUNGARY
- NIRX MEDIZINTECHNIK GMBH / GERMANY
- TELEMEDI GMBH / GERMANY

 Last updated: June 19, 2023

### LEGAL INFORMATION

#### Liability for Contents

The content of our pages has been compiled with utmost care. However, we do not assume any liability concerning the correctness, completeness and topicality of their content. In accordance with Article 7, Section 1 of the TMG (German Telemedia Act) we, as a service provider, are responsible for our own content on these pages in compliance with the general law. According to paragraphs 8 to 10 of the TMG, however, we are not obliged either to monitor third party information, which has been transferred or stored, or to search for circumstances that would indicate illegal activity. The responsibility to remove or block the use of information according to the general law shall remain unaffected. Any liability in this respect, however, is only possible from the moment at which knowledge of a specific violation of the law is obtained. We shall immediately remove this content upon discovery of such infringements.

#### Liability for Links

Our offer contains links to external websites of third parties, on the content of which we do not have any influence. Therefore, we cannot assume liability for this content. The liability for linked pages lies exclusively with their operators or providers. The linked pages were checked for possible legal violations at the time the links were created. Illegal content could not be identified at the time of setting the links. However, we cannot reasonably be expected to constantly monitor the content of the linked pages without any indication that the law has been violated. We shall immediately remove such links upon discovery of infringements.

#### Copyright

The content and works on these pages compiled by their operators are subject to German copyright law. Duplication, processing, distribution as well as any kind of exploitation, which lies beyond the limits of copyright law, requires the written consent of the respective author or originator. Downloads and copies from this page are only permitted for private, not commercial use. Insofar as the content of this page was not compiled by the operator, third party copyrights shall be observed. In particular, third party content shall be marked as such. In the event that you still become aware of a copyright violation, we kindly ask you to inform us accordingly. We shall immediately remove such content upon discovery of infringements.

# NBT Berlin 2023

## Conference Schedule

 The conference language is English

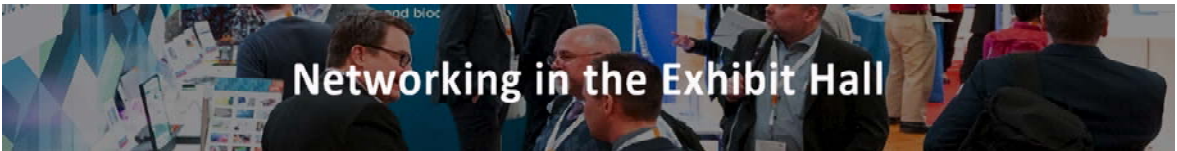

Day1: Tuesday, June 20, 2023	TIME	TOPIC	PRESENTER	COUNTRY
	9:30	Opening Remarks		
	9:40	EEG synthetic data generation using probabilistic diffusion models	TILBURG UNIVERSITY	THE NETHERLANDS
	10:00	An ultra-precise binocular laser pupillometer	QUANTUM BIOMETRONICS	GREECE
	10:20	Developing quality criteria for long-term testing of intracortical electrodes	FRAUNHOFER INSTITUTE FOR TOXICOLOGY AND EXPERIMENTAL MEDICINE ITEM	GERMANY
	10:50	Break		
	11:20	Neurofeedback to enhance response to hypnosis in individuals with multiple sclerosis	UNIVERSITY OF WASHINGTON	UNITED STATES
	11:45	Validation of in-ear EEG using full scalp EEG biomarkers	IDUN TECHNOLOGIES	SWITZERLAND
	12:15	Break		
	13:45	fNIRS hyperscanning, a live demonstration	NIRX MEDIZINTECHNIK GMBH	GERMANY
	14:15	A search for objective (EEG) criteria of subjective sleepiness	FED RES CTR FUNDAMENTAL & TRANSLAT MED	GERMANY
	14:40	Using the sense element engagement process to improve cortical prosthetic vision	INNER PSYCHOPHYSICS IP LLC	UNITED STATES
	15:05	Break		
	16:05	The BitBrain method for learning and inference at the edge	UNIVERSITY OF MANCHESTER	UNITED KINGDOM
	16:30	py_neuromodulation: A feature estimation and decoding platform for brain implants	CHARITE UNIVERSTITÄTSMEDIZIN BERLIN	GERMANY
	16:55	Networking		
18:00	End			

Day2: Wednesday, June 21, 2023	TIME	TOPIC	PRESENTER	COUNTRY
	9:30	Opening Remarks		
	9:40	Wearable neural sensors based on epitaxial graphene for hands-free robotic control	UNIVERSITY OF TECHNOLOGY SYDNEY	AUSTRALIA
	10:05	Non-invasive brain stimulation in sleep disorders: from electrophysiology to neuromodulation	UNIVERSITY OF CATANIA, CATANIA; OASI RESEARCH INSTITUTE-IRCCS, TROINA	ITALY
	10:30	Timeflux: an open-source python framework for brain-computer interfaces	TIMEFLUX	FRANCE
	10:55	Break		
	11:25	On the Stimulation Artifact Reduction during Electrophysiological Recording of Compound Nerve Action Potentials	FRAUNHOFER INSTITUTE FOR RELIABILITY AND MICROINTEGRATION IZM, BERLIN, GERMANY DELFT UNIVERSITY OF TECHNOLOGY, THE NETHERLANDS	GERMANY
	11:45	Assistive telehealth systems for neurorehabilitation	CANTERBURY CHRIST CHURCH UNIVERSITY	UNITED KINGDOM
	12:00	How artificial intelligence is shaping brain computer interface	GDANSK UNIVERSITY OF TECHNOLOGY	POLAND
	12:20	Navigating challenges in digital dementia intervention: A Look at BCI potential	METIS NEUROTEC, KARLSRUHE INSTITUTE OF TECHNOLOGY, FORSCHUNGSZENTRUM INFORMATIK (FZI)	GERMANY
	12:35	Break		
	14:05	Adaptable workflows for neural activity analysis in an open-source environment	FORSCHUNGSZENTRUM JÜLICH	GERMANY
	14:25	Signal Processing (with Questionable Labels) in Times of Uncertainty	HASSO PLATTNER INSTITUTE	GERMANY
	14:50	Industry use-cases of wireless EEG and EMG devices	MINDROVE KFT	HUNGARY
	15:05	PN Relay	POLITECNICO DI MILANO	ITALY
	15:25			
17:00	End			

/Be aware that the start and end times for each session are tentative. /This schedule is subject to change without prior notice. Check back for updates on [www.nbt-berlin.de](http://www.nbt-berlin.de). (Lasted updated: 16.06.2023)

# Assistive Telehealth Systems for Neurorehabilitation

Dr Hannan Azhar

email:hannan.azhar@canterbury.ac.uk , Canterbury Christ Church University, UK

Telehealth is an evolving field within the broader domain of Biomedical Engineering, specifically situated within the context of the Internet of Medical Things (IoMT). In today's society, the importance of Telehealth systems is increasingly recognized, as they enable remote patient treatment by physicians. One significant application in neurorehabilitation is Transcranial Direct Current Stimulation (tDCS), which has demonstrated its effectiveness in modulating mental function and learning is considered to be safe and widely accepted [1]. Furthermore, tDCS is widely accepted as a safe approach in the field. A non-invasive wearable tDCS device with integrated Internet connectivity was developed [1]. This IoMT device enables remote configuration of treatment parameters, such as session duration, current level, and placebo status. Clinicians can remotely access the device and define these parameters within the approved safety ranges for tDCS treatments. Experiment was conducted to test whether the parameters of a simulated treatment, which are tDCS session length, current state and placebo status, could be delivered to the tDCS device successfully (Fig. 1). The tDCS device screen showed 'Awaiting Physician Configuration'. The three parameters were then set, and once this was confirmed the treatment was able to commence, and the GUI stated, 'Treatment in Progress' (Fig. 1). Once the current was administered over the prescribed time the GUI stated, 'Treatment Stopped'. The GUI then confirmed 'Treatment Completed.' Each of these stages required confirmation from the Physician's CLI. The physician's interface ensured that only appropriate treatment ranges were used by parsing the parameters at the point of data entry.



Fig.1 – IoMT tele-tDCS

In addition to the wearable tDCS device, a prototype web portal is being developed to collect performance data during neurorehabilitation exercises conducted by individuals at home. This portal also facilitates remote interaction between patients and clinicians. To provide a platform-independent solution for accessing up-to-date healthcare information, a Progressive Web Application (PWA) is being developed [2]. The PWA enables real-time communication between patients and doctors through text chat and video conferencing. The primary objective is to create a cross-platform web application with PWA features that can function effectively as a native application in various operating systems. For offline functionality to be available, a service worker is required. The web app's real-time chat session, which is only available while online, is powered by WebSockets [2]. Patients and doctors can exchange text messages in real time without any unnecessary back-and-forth requests between the browser and server. The entire chat is saved in the database, allowing users to view the history of the conversation. Also, a video call can be initiated by either people in the chat conversation.

## References:

1. Steven David Herring, S.; Azhar, M. and Sakel, M. (2022). "Tele-tDCS: A Novel Tele-neuromodulation Framework using Internet of Medical Things". In Proceedings of the 15th International Joint Conference on Biomedical Engineering Systems and Technologies (BIOSTEC 2022) - BIODEVICES; pages 84-93. DOI: 10.5220/0010882500003123.
2. M. A. Hannan Bin Azhar and J. T. Mohan, "Progressive Web App for Real-time Doctor-Patient Communication and Searchable Health Conditions," 2022 E-Health and Bioengineering Conference (EHB), Iasi, Romania, 2022, pp. 1-5, doi: 10.1109/EHB55594.2022.9991288.



# py\_neuromodulation: A feature estimation and decoding platform for brain implants

Timon Merk<sup>1</sup>, Richard M. Köhler<sup>1</sup>, Victoria Peterson<sup>2,3</sup>, Laura Freire Lyra<sup>1</sup>, Jonathan Vanhooeke<sup>1</sup>, Meera Chikermane<sup>1</sup>, Ningfei Li<sup>1</sup>, Ashley Walton<sup>2</sup>, Alan Bush<sup>2</sup>, Nathan Sистерson<sup>2</sup>, Johannes Busch<sup>1</sup>, Roxanne Lofredi<sup>1</sup>, Jeroen Habets<sup>1</sup>, Julius Huebl<sup>1</sup>, Witek Lipski<sup>4</sup>, Thomas S. Binns<sup>1,5</sup>, Vasileios Kokkinos<sup>2,6</sup>, Guanyu Zhu<sup>7</sup>, Zixiao Yin<sup>7</sup>, Baotian Zhao<sup>7</sup>, Patricia Krause<sup>1</sup>, Katharina Faust<sup>8</sup>, Gerd-Helge Schneider<sup>8</sup>, Andreas Horn<sup>9,10</sup>, Jianguo Zhang<sup>7</sup>, Andrea A. Kühn<sup>1</sup>, R. Mark Richardson<sup>2</sup>, Wolf-Julian Neumann<sup>1,5</sup>

<sup>1</sup>Movement Disorder and Neuromodulation Unit, Department of Neurology, Charité – Universitätsmedizin Berlin, Charitéplatz 1, 10117 Berlin, Germany, timon.merk@charite.de

<sup>2</sup>Department of Neurosurgery, Massachusetts General Hospital, Harvard Medical School, Boston, USA

<sup>3</sup>Instituto de Matemática Aplicada del Litoral IMAL, CONICET-UNL, Santa Fe 3000, Argentina

<sup>4</sup>Department of Neurological Surgery, University of Pittsburgh, School of Medicine, Pittsburgh, PA, USA

<sup>5</sup>Einstein Center for Neurosciences Berlin, Charité – Universitätsmedizin Berlin, Charitéplatz 1, 10117 Berlin, Germany

<sup>6</sup>Epilepsy Clinical Neurophysiology, Northwestern Memorial Hospital: Chicago, Illinois, US

<sup>7</sup>Department of Neurosurgery, Beijing Tiantan Hospital, Capital Medical University, Beijing, China; Beijing Key Laboratory of Neurostimulation, Beijing, China.

<sup>8</sup>Department of Neurosurgery, Charité – Universitätsmedizin Berlin, Charitéplatz 1, 10117 Berlin, Germany

<sup>9</sup>Department of Neurology, Harvard Medical School, Boston, Massachusetts

<sup>10</sup>Center for Brain Circuit Therapeutics, Brigham & Women's Hospital, Boston, Massachusetts

Brain computer interfaces (BCI) offer high precision for treating brain disorders, but there is a lack of standards for integrating data and estimating features using machine learning. To address this issue, we present a software framework called py\_neuromodulation that combines adaptive deep brain stimulation and connectomics to facilitate brain circuit discovery for brain implants. We tested this platform on data from 73 patients with movement disorders, depression, and epilepsy. We identified Network targets for emotion decoding in depression patients, performed generalized movement decoding across cohorts with Parkinson's disease from the US, Europe, and China, and improved seizure detection in responsive neurostimulation for epilepsy. The platform's capabilities aid precision medicine by enabling personalized therapy for patients with brain disorders.

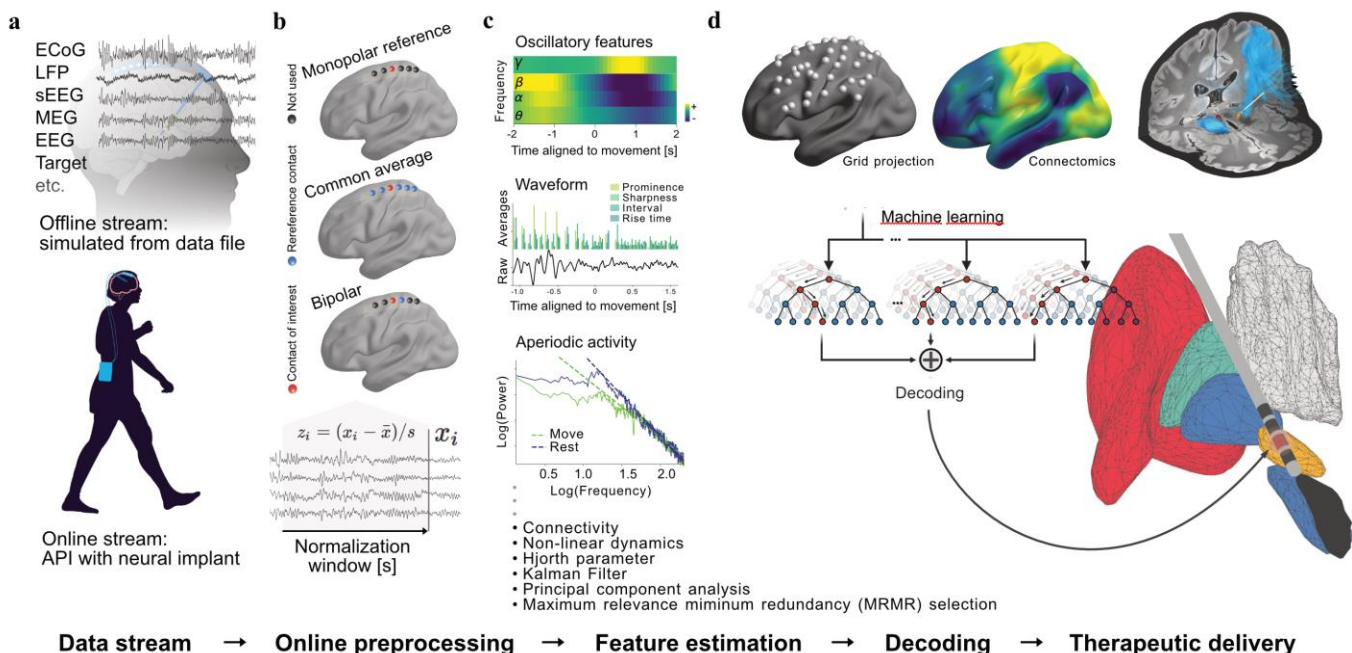



## A search for objective (EEG) criteria of subjective sleepiness

Arcady A. Putilov

Nipkowstr. 11, 12489 Berlin, Germany

Federal Research Centre for Fundamental and Translational Medicine, Novosibirsk, Russia

The dominated methodology for study substates of wake states differs from the methodology for the studying sleep substates (i.e., sleep stages). Unlike sleep substates, sleepiness substate of wake state has not been yet clearly separated from other wake or sleep substates by applying objective polysomnographic criteria including the electroencephalographic (EEG) criteria. On the other hand, sleepiness, unlike sleep substates, can be consciously perceived by anybody, and, therefore, it can be assessed with a questionnaire. However, research of the subjective concept of sleepiness produced many controversial questions, including such questions as whether the physiological component of subjective feeling of sleepiness can be precisely defined in scientific terms, and whether the reliable physiological markers of subjective sleepiness (e.g., its EEG marker) can be identified. We revealed the EEG-underpinnings of subjectively assessed sleepiness in the study of afternoon napping attempts of university students and concluded that the self-reports of these students on excessive daytime sleepiness can be trusted because 1) they demonstrated the signs of elevated sleep pressure during such napping attempts and 2) they are chronically sleep deprived during weekdays (when they are attending classes).

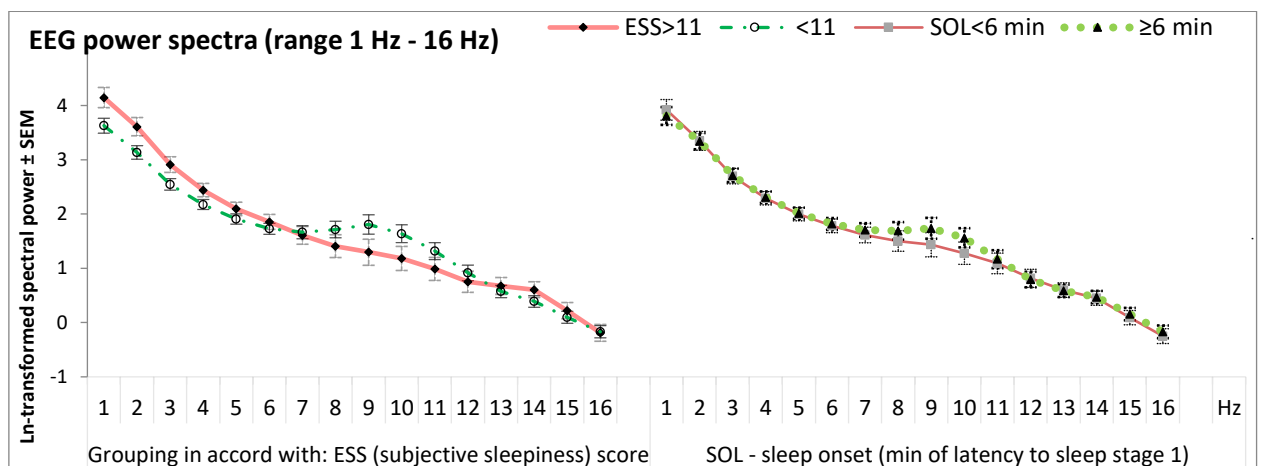

# Adaptable workflows for neural activity analysis in an open-source environment

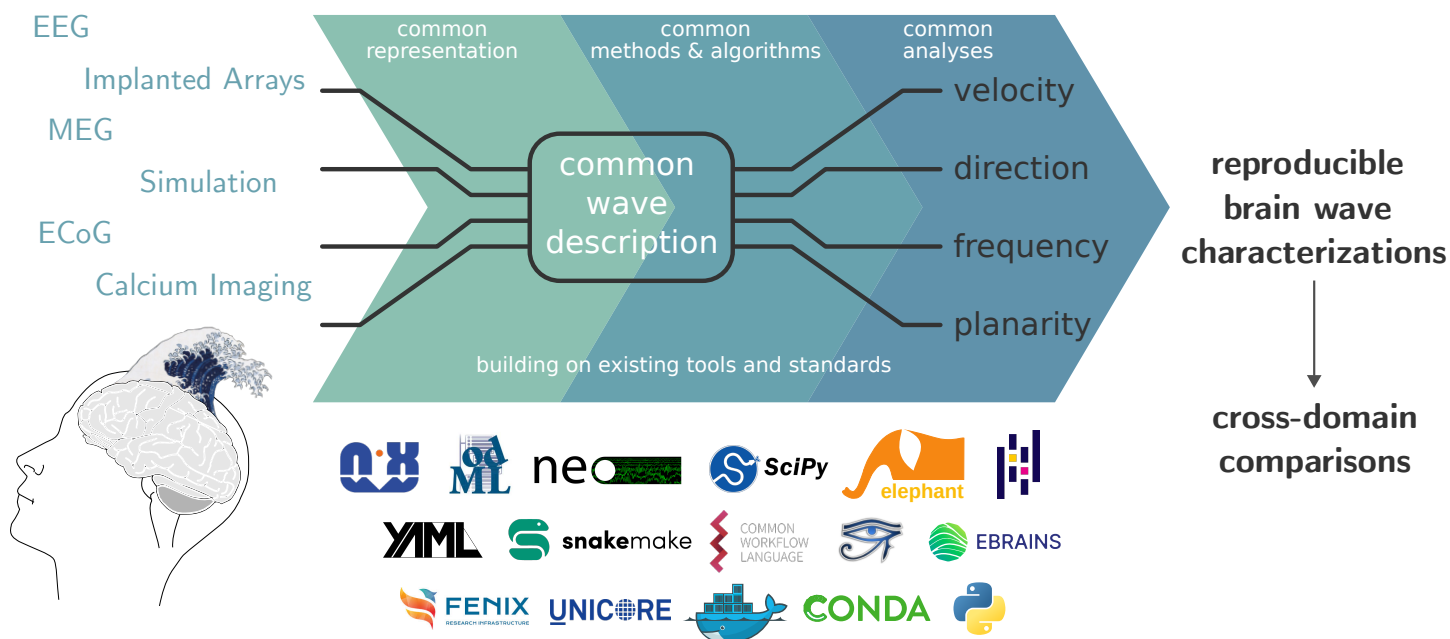

The coherence of neural activity analysis is challenged by an increasing heterogeneity of measurement devices, analysis tools, and data formats. The Collaborative Brain Wave Analysis Pipeline (Cobrawap) is an adaptable and reusable analysis workflow solution for studying cortical wave activity. By leveraging the open-source software ecosystem, its modular approach allows the construction of reproducible workflows through seamless chaining of method blocks. Its inherent adaptability supports the processing of data from various measurement techniques and simulations, and the reuse and extension for wide-ranging research applications, thus demonstrating that an open and modular approach can improve automation, integrate diverse methods, and enable comprehensive cross-domain comparisons.

**Contact:** Robin Gutzen  
r.gutzen@fz-juelich.de



- adaptable ✓
- reusable ✓
- extendable ✓

<https://cobrawap.readthedocs.io>

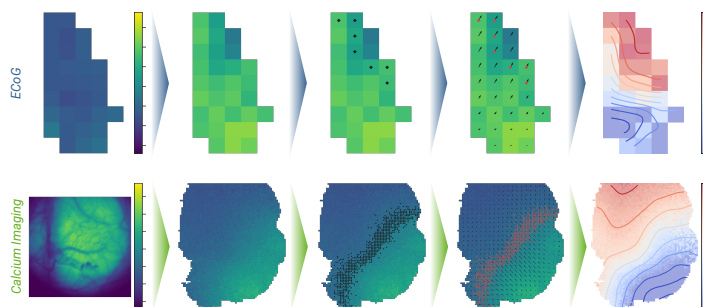

Gutzen et al. (2022) arxiv  
doi:10.48550/arXiv.2211.08527

# On the Stimulation Artifact Reduction during Electrophysiological Recording of Compound Nerve Action Potentials

Raphael Panskus<sup>1,2</sup>, Lukas Holzapfel<sup>2</sup>, Wouter A. Serdijn<sup>1,3</sup> and Vasiliki Giagka<sup>1,2</sup>

**Abstract:** Recording neuronal activity triggered by electrical impulses is a powerful tool in neuroscience research and neural engineering. It is often applied in acute electrophysiological experimental settings to record compound nerve action potentials. However, the elicited neural response is often distorted by electrical stimulus artifacts, complicating subsequent analysis. In this work, we present a model to better understand the effect of the selected amplifier configuration and the location of the ground electrode in a practical electrophysiological nerve setup. Simulation results show that the stimulus artifact can be reduced by more than an order of magnitude if the placement of the ground electrode, its impedance, and the amplifier configuration are optimized. We experimentally demonstrate the effects in three different settings, in-vivo and in-vitro.

**Method:** A typical peripheral nerve setup and respective topologies were modelled using simplified lumped models in LTspice. Different ground electrode impedances, placements and amplifier configurations were simulated. We also tested the feasibility of the ground electrode configuration in-vitro and in-vivo on earthworms to mimic the nerve tissue.

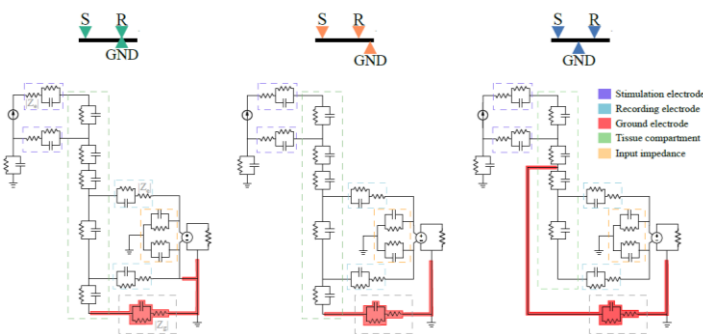

Topologies of the electrical equivalent circuit models single-ended configuration (left), differential configuration with ground electrode placed distal to recording and stimulation side (middle) and differential configuration with the ground electrode placed between (right)

<sup>1</sup>Dept. of Microelectronics, Faculty of Electrical Engineering, Mathematics and Computer Science, Delft University of Technology, The Netherlands.

<sup>2</sup>Dept. of System Integration and Interconnection Technologies, Fraunhofer Institute for Reliability and Microintegration IZM, Berlin, Germany.

<sup>3</sup>Neuroscience Dept., Erasmus Medical Center, Rotterdam, the Netherlands.

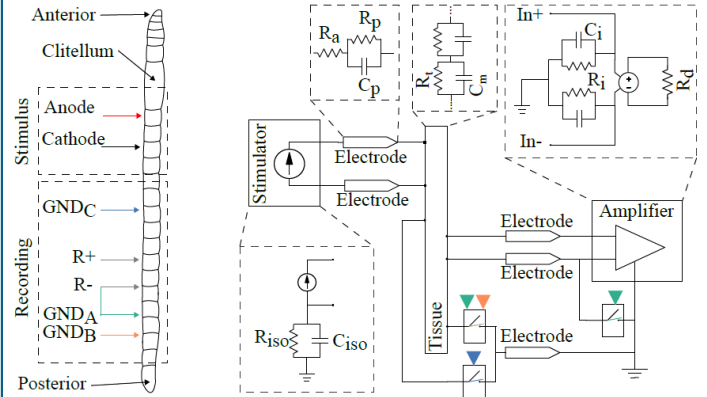

Schematic representation of a typical experimental setup configuration, with electrode placement on an earthworm (left) and electrical equivalent circuits (right).

## Results:

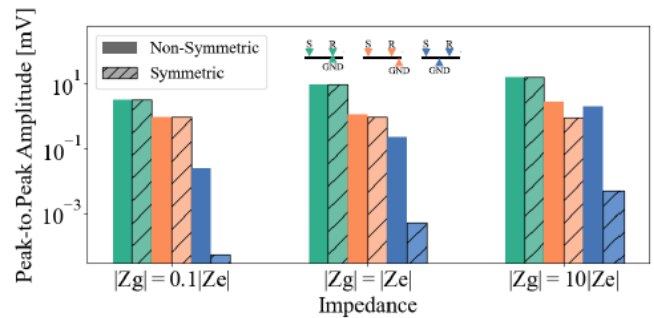

Simulation results of stimulation artifact for different topologies.

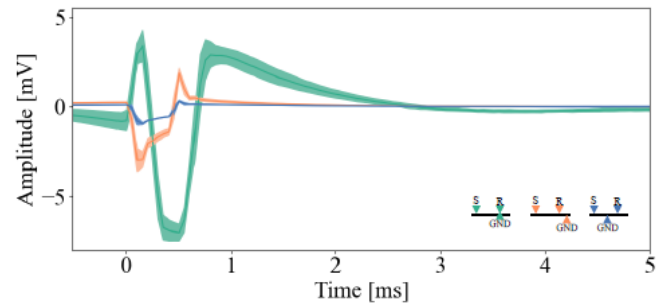

Recorded stimulation artifact in-vitro for different topologies.

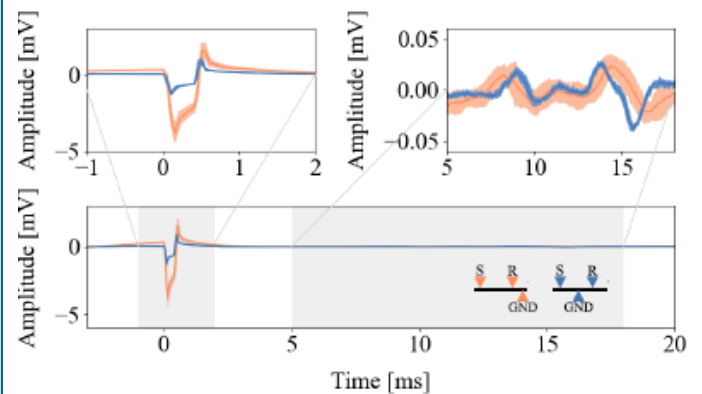

Averaged stimulation artefact and compound action potentials.

# TRANSFER LABORATORY Fraunhofer NEUROTECHNOLOGY: ITEM EVALUATION OF LONG-TERM IMPLANTS

Finding decisions early with more certainty

As lifespan increases, implants also stay in the body longer and are subjected to greater stress. We perform individually developed long-term *in vivo* testing for implants to gain valuable insights, e.g. how the implants behave when exposed to body fluids, and under mechanical impact in the body. These findings enable making a qualitatively well-founded decision in the development process to avoid considerable extra resources and costs.

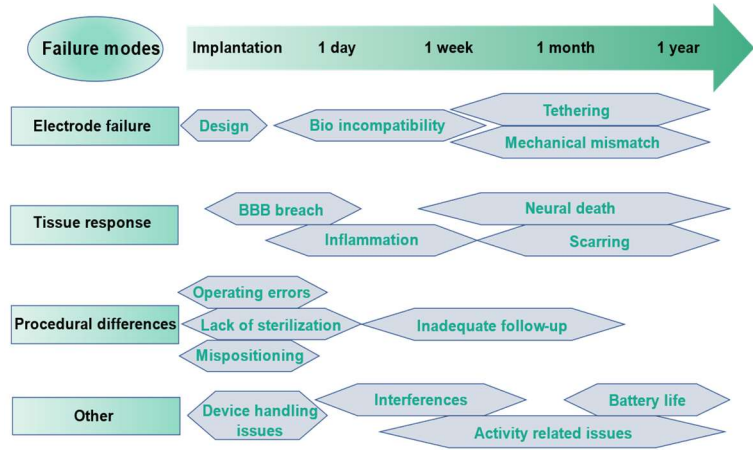

*Tissue reactions and electrophysiology of neuroimplants and materials*

Patients expect implant manufacturers to provide reliable state-of-the-art implants for long-term application. The process of CE-marking or FDA registration only states that overall, the legal requirements for performance and safety have been met. It does not require long-term functional testing *in vivo*.

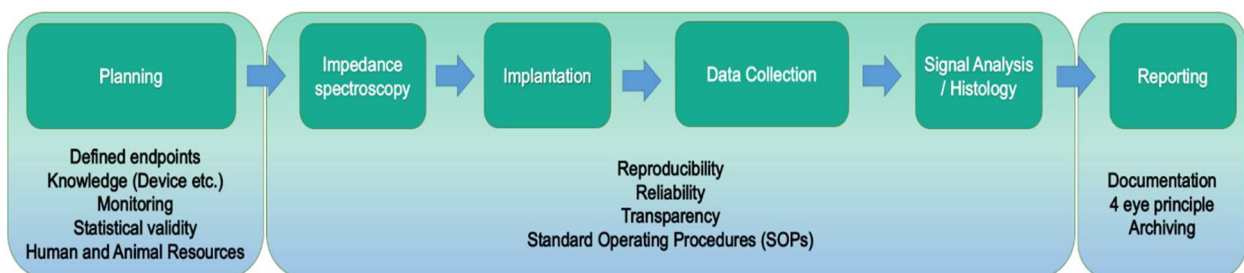

*Defined quality criteria for long-term testing of neuroimplants*

We develop an individual evaluation matrix and define the evidence levels, such as signal-to-noise ratio (SNR), isolation distance and L-ratio. Compatible processes are developed and established for implant evaluation, including histological tissue assessment for several time points after implantation. These defined evidence levels and processes enable the creation of quality criteria for efficient implant testing. In addition, advanced testing in the development process with clearly defined quality criteria helps to find the right decisions early on, reduce development risk, animal testing in later phases and saves costs.

## Fraunhofer Institute for Toxicology and Experimental Medicine ITEM

Nikolai-Fuchs-Straße 1  
30625 Hannover

Contact:  
Dr. Ulrich Froriep  
Phone +49 511 5350-2944  
ulrich.froriep@item.fraunhofer.de  
www.item.fraunhofer.de

# how artificial intelligence is shaping brain computer interface

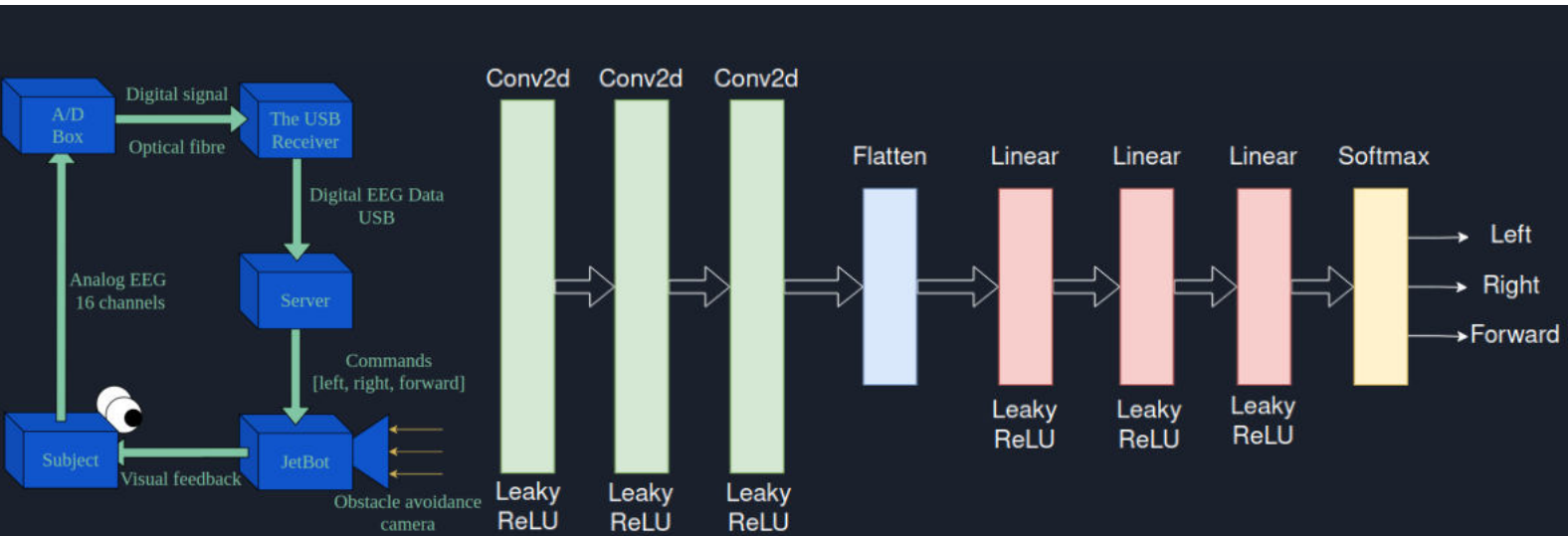

Artificial intelligence (AI) is revolutionizing the field of brain-computer interfaces (BCIs) by enhancing their capabilities and expanding their potential applications. AI algorithms analyze and interpret neural signals, enabling more accurate and efficient communication between the brain and external devices. This fusion of AI and BCIs holds promise for advancements in neuroprosthetics, cognitive enhancement, and medical treatments for neurological disorders. By harnessing the power of AI, BCIs are becoming increasingly sophisticated, user-friendly, and capable of transforming the lives of individuals with disabilities, enhancing human cognition, and unlocking new frontiers in human-machine interaction.

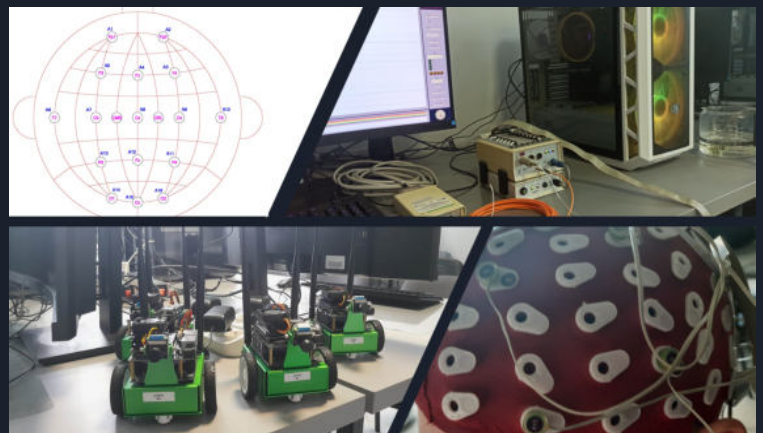
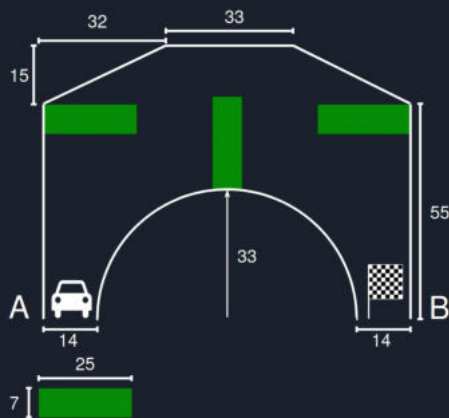

Nikodem Matuszkiewicz  
Jakub Kwiatkowski  
Piotr Durawa  
Aleksander Madajczak  
Tomasz Kocejko

brainBot  
  
developers

s175867@student.pg.edu.pl  
tomkocej@pg.edu.pl

# Signal Processing (with Questionable Labels) in Times of Uncertainty

Christoph Anders, Sidratul Moontaha  
 Digital Health — Connected Healthcare, Hasso Plattner Institute, University of Potsdam, Germany.  
 Correspondence: [firstname.lastname@hpi.de](mailto:firstname.lastname@hpi.de)

**Overview:** Up to this day, most experiments and data analysis techniques focus on data recorded inside laboratory environments or simulations. However, life does not happen inside a laboratory but instead occurs mostly outside of it. There exists a gap between well-established data analysis methods and their applicability to data recorded in daily life. We conducted a user-centered study to provide methods for researchers to analyze physiological data from multi-modal EEG, PPG, and EDA sensors when participants are under mental workload and stress in daily life. While using laboratory measurements as reference data, we discuss some challenges encountered and the first insights we gained in working with data from uncontrolled environments.

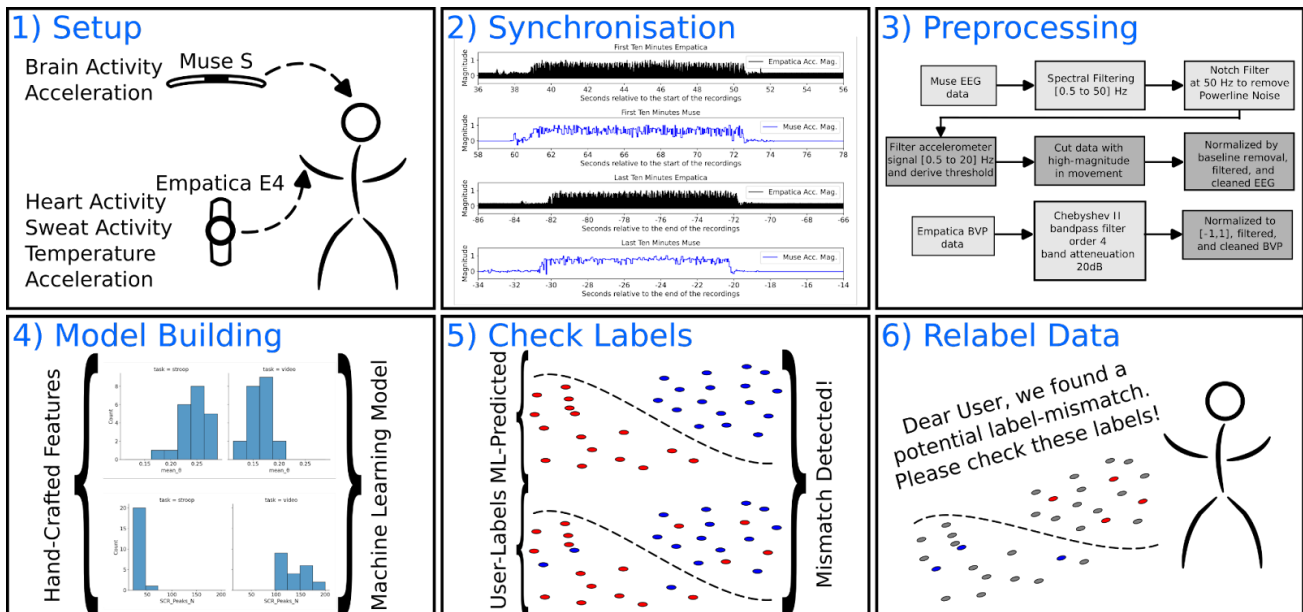

Data available at: <https://doi.org/10.5281/zenodo.7923969>  
 ML-Pipeline Code available at: <https://github.com/HPI-CH/cosmos>  
 PsychoPy Study Module available at: [https://github.com/HPI-CH/PsychoPy\\_COSMOS](https://github.com/HPI-CH/PsychoPy_COSMOS)  
 Persona Sidratul Moontaha: <https://hpi.de/arnrich/people/sidratul-moontaha.html>  
 Persona Christoph Anders: <https://hpi.de/arnrich/people/christoph-anders.html>

# USING THE SENSE ELEMENT ENGAGEMENT PROCESS

## TO IMPROVE CORTICAL PROSTHETIC VISION

Raymond Pavloski

[rpavloski@innerpsychophysicsip.com](mailto:rpavloski@innerpsychophysicsip.com)

INNER  
PSYCHOPHYSICS  
IP LLC

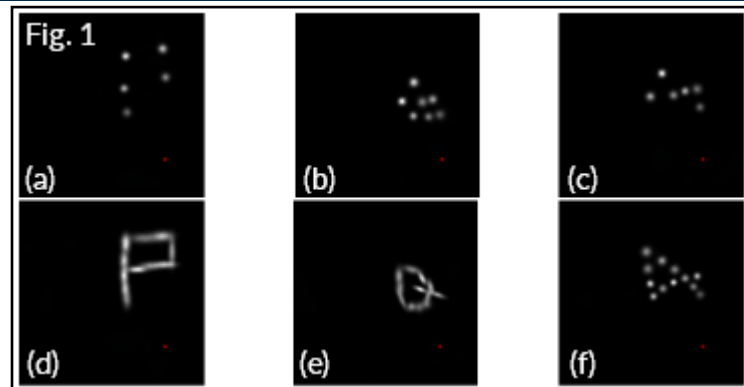

**Introduction** Our goal is to use the sense element engagement process [1,2,3] to devise a neuromorphic device which modulates the amplitude of electrical stimulation of visual cortex to produce a continuous form such as 1(d) or 1(e) or a recognizable shape such as 1(f) rather than a typical pattern of phosphenes such as 1(a) or 1(b) or 1(c). This process portrays phosphenes in visual space as sensible physical patterns that result from interactions mediated by two systems of synapses within a visual cortex neural network. Activation of a lightness (L) system of synapses is proposed to underlie lightness interval distribution patterns (i.e., phosphenes) on a visual geometry pattern that results from activation of a geometric (G) system of synapses. L strengths decrease with differences in lightness between visual regions and G strengths decrease with distances on the visual geometry.

Simulations of a recurrent neural network composed of spiking neurons [1,2,3]: (1) demonstrate the predicted emergence of continuous G and L synaptic interactions as the frequency of excitatory spikes delivered to network neurons (control parameter) reaches a critical value; (2) yield distributions of spike frequencies over the cortical columns of the network that can be used to classify the expected number of phosphenes both for a normal geometry producing phosphenes as in 1(a) and for an altered geometry producing a continuous form as in 1(d); and (3) have been combined with emulation of a neuromorphic device employing extrinsic G synapses that intermittently delivers stimulation the amplitude of which is modulated by intermittent population recordings.

The aim of the research reported here is to determine if parameters of the simulations must be altered in order to produce similar spike distributions and correct classifications of the number of phosphenes in simulations that do and do not include the neuromorphic device.

**Methods** The PyNEST interface to the NEST simulator [4,5] was used with a time step of 0.05 ms and a simulation duration of 10 s. The network consisted of four excitatory and two inhibitory neurons in each of 49 columns corresponding to the 49 visual regions shown in Fig. 2. Each simulation was run using frequencies of 40, 50, and 60 excitatory spikes/s delivered to network neurons (control parameter). G strengths decreased with distances within and between the regions shown in Fig. 2 for normal visual geometry simulations. In altered geometry simulations regions 4 and 5 were made equal to the union of regions 1,4, and 5 and G strengths reflected this change. In half of the simulations a neuromorphic neuron controlled the

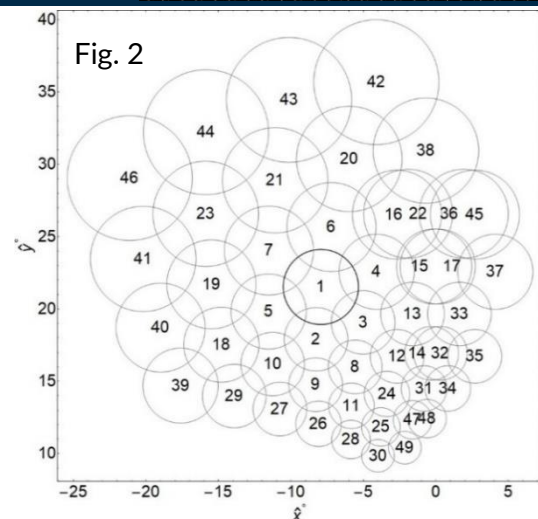

amplitude of simulated stimulation of neurons in each of columns 1, 4, 5, and 12 on the basis of activity in extrinsic G system synapses that receive spikes generated from population activity. Network-only simulations used recordings of stimulation amplitudes produced by the neuromorphic device.

**Results** The number of phosphenes is classified perfectly for simulations that are based on either the normal or the altered geometry, and classification accuracy > 99% for combined normal and altered visual geometry data. A total of 61 errors are made in classifying 12,480 spike frequency distributions. 37 misclassifications occur using data from network-alone simulations and 24 misclassifications occur using data from simulations that include the neuromorphic device. Thus, creating a second visual geometry by using the device produces results that are at least as accurate as results that are based on changing G system synaptic strengths in the neural network.

**Conclusions** Simulation results suggest that a neuromorphic device may improve the utility of existing cortical prosthetic vision systems. Although the neuromorphic device has not yet been tested by blind implant recipients, the fact that spike frequency distributions carry information on the number of phosphenes, an aspect of experience, demonstrates that a device can be built that at a minimum behaves as though it experiences phosphenes as humans do. The sense element engagement process can be applied to other aspects of experience that can be modeled in reference to neural activity.

### References

- [1] Pavloski, R. Progress in Developing an Emulation of a Neuromorphic Device That Is Predicted to Enhance Existing Cortical Prosthetic Vision Technology by Engaging Desired Visual Geometries. *Prosthesis* 2022, 4, 600–623. <https://doi.org/10.3390/prosthesis4040049>
- [2] Pavloski, R. Sense Element Engagement Theory Explains How Neural Networks Produce Cortical Prosthetic Vision. Available online: [https://www.techrxiv.org/articles/preprint/Sense\\_Element\\_Engagement\\_Theory\\_Explains\\_How\\_Neural\\_Networks\\_Produce\\_Cortical\\_Prosthetic\\_Vision/17161187/1](https://www.techrxiv.org/articles/preprint/Sense_Element_Engagement_Theory_Explains_How_Neural_Networks_Produce_Cortical_Prosthetic_Vision/17161187/1).
- [3] Pavloski, R. Sense Element Engagement Process of Cortical Prosthetic Vision by Neural Networks. US Patent Application No. 18/063,232; PCT International Patent Application No. PCT/US22/81153.
- [4] Eppler, J.M.; Helias, M.; Muller, E.; Diesmann, M.; Gewaltig, M.-O. PyNEST: A convenient interface to the NEST simulator. *Front. Neuroinf.* 2008, 2, 12. <https://doi.org/10.3389/neuro.11.012.2008>.
- [5] Fardet, T.; Vennemo, S.B.; Mitchell, J.; Mørk, H.; Graber, S.; Hahne, J.; Spreizer, S.; Deepu, R.; Trensche, G.; Weidel, P.; et al. NEST 2.20.0 (2.20.0). Zenodo. Available online: <https://doi.org/10.5281/zenodo.3605514>.

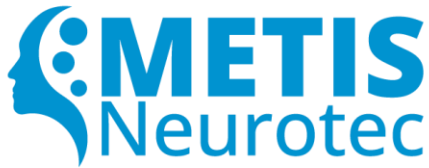

Worldwide, only 20-50% of all cases of dementia are being diagnosed. Therefore, there is a significant deficit in recognizing and treating the neurological disorder. However, almost 90% of doctors and patients surveyed demand early diagnosis to react to associated changes in care and everyday life.

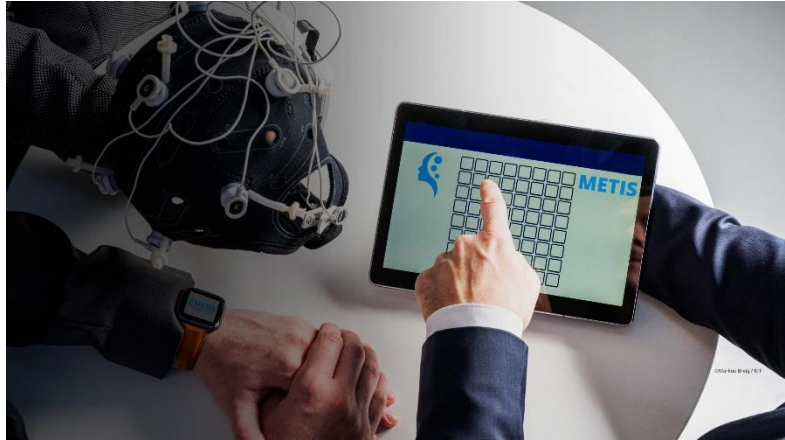

For this reason, the German federal government approved a national dementia strategy in 2020. However, tools for the early treatment of dementia are not widely available.

According to recent studies, around one-third of all cases of dementia can be prevented or at least positively influenced in their course by timely treatment of specific risk factors. The starting point for METIS is the scientific consensus that neurological disorders such as dementia are multi-factorial processes reflected in declining memory performance due to individual risk profiles.

**METIS** develops a digital platform that accompanies a multi-stage process to provide low-threshold access to individualized treatment strategies for neurodegenerative diseases in an outpatient setting. With the help of digital platform-based methods and technologies for controlling risk factor-based intervention strategies, this treatment process is integrated into a mobile support solution and accompanied by various tools. These include the use of AI for the personalization of treatment of patient specific risk-profiles and direct contact with medical professionals. The system is completed by employing modern wearables to fine-tune the patient's holistic health profile and intervention plan.

**Help us to stop dementia.**

get in contact with us



**Dr. Markus Schinle**  
Schinle@MetisNeurotec.com



**Marius Gerdes**  
Gerdes@MetisNeurotec.com



**Dr. Simon Stock**  
Stock@MetisNeurotec.com



# Join the leading and most published mobile fNIRS research platform.



From high-end entry-level systems to high-density whole head.



NEW: Fully integrated physiology NIRxWINGS (pulse oximetry (PPG), heart-rate, heart-rate variability (HRV), oxygen saturation (SpO2), respiration, temperature, galvanic skin response (GSR), and bipolar signals such as EMG and ECG).



Superior short-channel solution 8mm & sensor-level motion sensors.



Multimodal integration with EEG, TMS, fMRI, eye-tracking, and more.



Laser and APD extension for full MR compatibility.



Free support by fNIRS experts, our goal is to get you to publish fast.



NEW: Satori commercial fNIRS software in cooperation with Brain Innovation.



Anatomically correct baby and infant head models.



# The PN Relay Project

Antonio Coviello & PNRelay Team  
Department of Electronics, Information and Bioengineering (DEIB), Politecnico di Milano, Milan, Italy  
antonio.coviello@polimi.it

Peripheral neuropathies pose a growing clinical concern that demands careful attention. Considering the high number of affected individuals, it is crucial to address the complexities associated with this condition by developing alternative approaches to the conventional medicine. The impact of peripheral nerve injuries on patients' daily lives is profound, resulting in sensory and motor impairments within the innervated regions of the body, which often leads to partial or complete paralysis of the affected area. Although nerve regeneration surgery has shown moderate success rates around 40% for motor and sensory recovery, current advancements in biological and cellular strategies, both in clinical and preclinical settings, fall short in achieving complete functional restoration [1, 2, 3].

Thus, there is a pressing need to develop new strategies that leverage emerging technologies. In recent years, significant progress has been made in the development of neuroprostheses, which aims to bypass the site of injury and restore bidirectional information flow to the central nervous system. Although open-loop control of upper and lower limb movement has shown promising results, incorporating sensory neural feedback into prosthetic devices remains a substantial challenge. An idea of implanted system is shown in Fig. 1, which provides a schematic representation of a potential implanted neuroprosthetic device designed to restore hand function. The device detects the electroneurogram (ENG) of a peripheral nerve signal in the vicinity of the injury. Then, the sampled signal is transmitted beyond the injured segment to artificially stimulate the target nerve or organ, replicating the body's neural response [1, 2, 3].

The main aspects and technologies that will be covered in the presentation are the following: i) analysis of signals to extract the information in the detected signal and its subsequent classification with machine learning methods; ii) definition of the current CE/FDA regulations to make the device compliant for any use on a patient; iii) creation of a biomedical and compatible casing for containing the device to be implanted; iv) neuromodulation for selective nerve stimulation and subsequent motor rehabilitation to reproduce evoked potentials; v) data compression to satisfy constraints of Bluetooth data transmission; and vi) wireless power transfer to supply the implanted device.

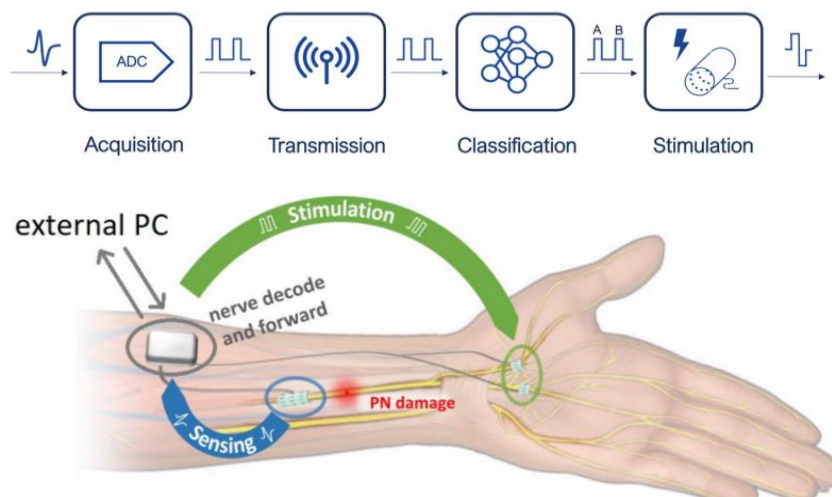

Fig. 1. Pictorial description of the implanted PNRelay system in a hand [1,2].

- [1] A. Coviello, F. Porta, et al., "Neural network-based classification of ENG recordings in response to naturally evoked stimulation". J. Proceedings of the 9th ACM International Conference on Nanoscale Computing and Communication, 10-2022, pp. 1-7, doi:<https://doi.org/10.1145/3558583.3558855>
- [2] E. Vasta, A. Coviello, et al., "Classification of Sensory Neural Signals through Deep Learning Methods". To be presented at IEEE EUROCON 2023, 7-2023.
- [3] A. Coviello, A. Bersani, et al., "Comparison of Data Compression Methods for Implanted Real-Time Peripheral Nervous System", submitted.

# An ultra-precise binocular laser pupillometer

Iannis Kominis

Department of Physics, University of Crete, Heraklion 71003 Greece

Quantum Biometrics PC, Heraklion 71409 Greece

We will present a new binocular laser pupillometer, aimed to study the pupil light reflex with unprecedented precision. The laser pupillometer provides for the first time precise spatially-selective illumination of the eye and stimulation of the retina. It combines visible and infrared laser light, the former used for stimulus, and the latter for providing pointing information. The spatial selectivity provides order-of-magnitude increase in the neural information that can be extracted from measurements of the pupil diameter dynamics, and thus can lead to novel methodologies for addressing brain function and developing new medical diagnostic tools.

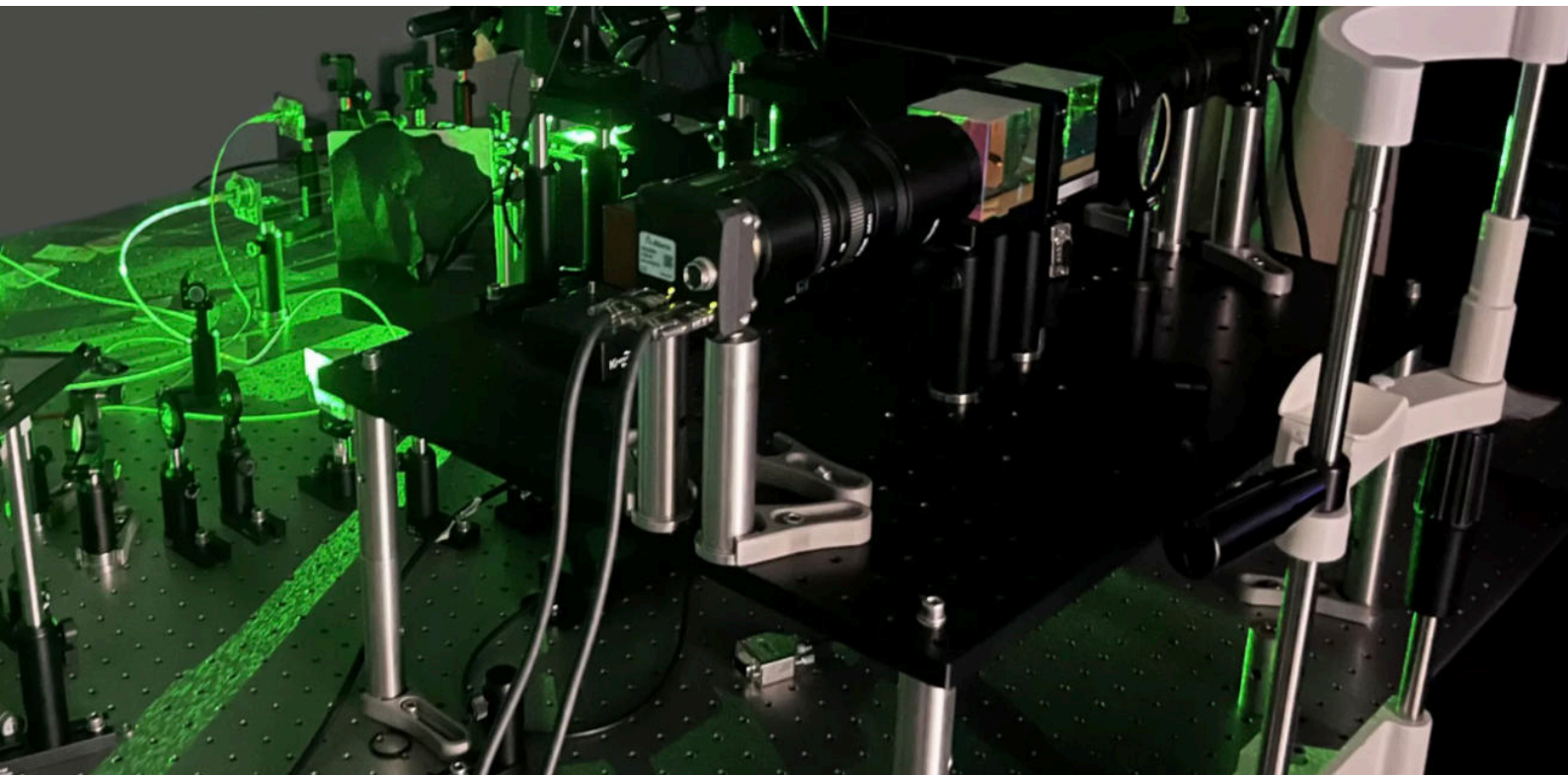
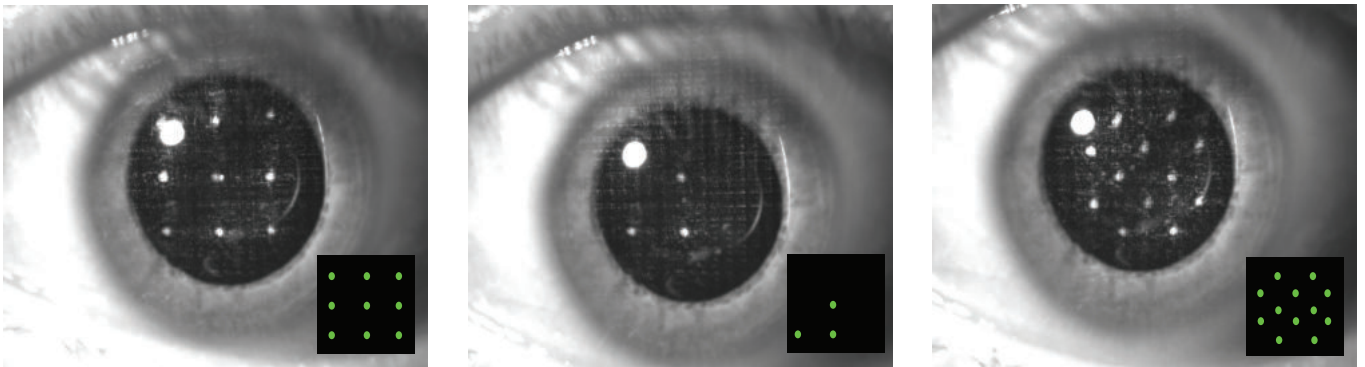

# EEG SYNTHETIC DATA GENERATION USING PROBABILISTIC DIFFUSION MODELS

## AUTHORS

Giulio Tosato  
g.tosato@tilburguniversity.edu

Cesare Maria Dalbagno  
c.m.dalbagno@tilburguniversity.edu

Francesco Fumagalli  
f.fumagalli@tilburguniversity.edu

This study proposes a method to generate synthetic Electroencephalography (EEG) data using denoising diffusion probabilistic models (DDPMs) to address the challenge of obtaining sufficient EEG data for training deep learning techniques in Brain-Computer Interface (BCI) applications. Synthetic data was validated through comparisons with real EEG data, furthermore in the paper implications of this technique for neuroscience research by enabling the creation of large, publicly available synthetic EEG datasets are discussed.

## METHODS

EEG is a safe and portable brain imaging technique that measures electrical activity using scalp electrodes (M. Teplan, 2002). The **Short-time Fourier Transform (STFT)** divides a nonstationary time series into smaller segments and performs a Discrete Fourier Transform (DFT), providing time-localized frequency information, which allows for EEG recordings analysis (Shovon et al., 2019; Palus, 1996).

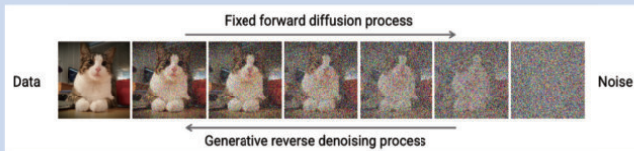

DDPMs are generative models which gradually add Gaussian noise to the data, and then learn to reverse the diffusion process to create synthetic samples (in the image above). We used OpenAI improved-diffusion, which has demonstrated exceptional performance (Nichol & Dhariwal, 2021). A Pytorch (Paszke et al, 2017) classifier was developed for multiple classes.

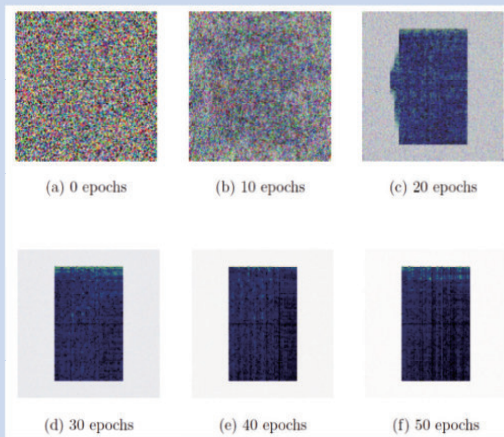

Images generated by the Diffusion Model during training (each image is generated upside down, with the x-axis representing the channels and the y-axis representing the frequencies).

## PROCEDURE

For this study, EEG emotionally labeled data (happy-sad) from the SEED V dataset was preprocessed and Electrode-frequency Distribution Maps (EFDMs) were created using MNE-Python library and the STFT function. The EFDMs are 2D arrays representing grayscale images of intensity values in each channel at each frequency (Gramfort et al., 2013; Wang et al., 2020). The classifier was trained on 24000 images per emotion (same as the diffusion model), and accuracy was evaluated on a separate dataset of 6000 images per emotion, we also adapted the OpenAI diffusion model (code available GitHub repository). We tested the performance of the classifier, trained with real data for 20 epochs, on synthetic data; achieving an average of over 90% accuracy, therefore assessing the reliability of the generated data.

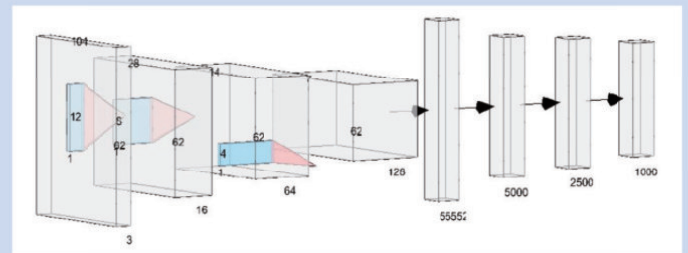

Classifier Architecture

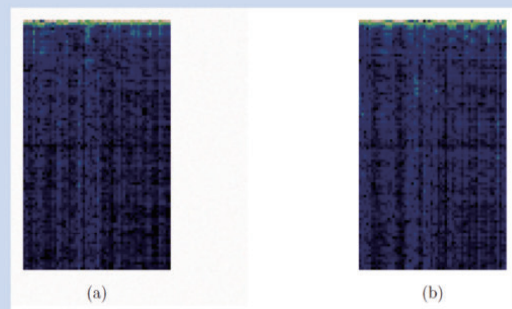

Comparison between a synthetic image generated by the Diffusion Model trained for 60 epochs (a) and an original image (b).

## DISCUSSION

Concerns of overfitting with the diffusion model were tested by training the classifier on both synthetic and real data and comparing its performance with a model trained solely on real data. The results showed that using synthetic data in combination with real data can improve the accuracy of classifiers, suggesting that generated data contains unique information.

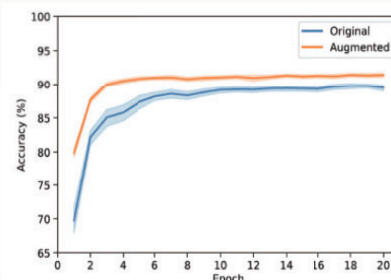

Comparison of validation across 20 runs of the same model trained with original data only and 20 runs trained with both original and synthetic data, generated by a diffusion model trained for 60 epochs.

## CONCLUSION

Individual differences in brain activity pose challenges for patient-specific DeepLearning-based BCIs. A future project is to use few-shot learning to fine-tune a large pretrained model on limited data from an individual, creating a personalized dataset and improving model performance while reducing sampling time and costs for EEG scans. Moreover, this type of data can be shared without privacy concerns, thereby fostering research and applications on brain activity.





# TIMEFLUX - an open-source Python framework for building Brain-Computer Interfaces

Paper, documentation, downloads  
<https://timeflux.io>



## In a nutshell

- Fits well within the **Python datascience ecosystem**
- Permissive **MIT license**: commercial use authorized
- Works both **offline** and **online**
- **Quick prototyping**

## Easy to learn, use, and extend

- **Familiar concepts**: graphs, nodes, edges
- Relies on **industry standards**: Pandas, Xarray, Scikit-Learn, Lab Streaming Layer
- **Descriptive pipelines**: simple YAML syntax, no coding required
- **Custom nodes**: standard Python classes

## Batteries included

- **Networking**: Pub/Sub, Lab Streaming Layer, OSC, WebSocket
- **Recording and replay**: HDF5 file format
- **Digital Signal Processing**
- **Machine Learning**
- **User interface**: monitoring, web apps
- Multidimensional **matrix manipulation**: queries, expressions, epoching, windowing
- Native **device drivers**
- Sub-millisecond **time synchronization**
- **Debugging** tools
- Compatible with **all kinds of time series**: not only for EEG data
- Runs on Linux, MacOS and Windows

## It happens in the browser

- **JavaScript API** to interact with Timeflux instances from the browser
- Bidirectional **streaming**
- **Precisely timed** stimuli and events: suitable for SSVEP and ERP research
- **Easy integration** with behavioral frameworks and game engines

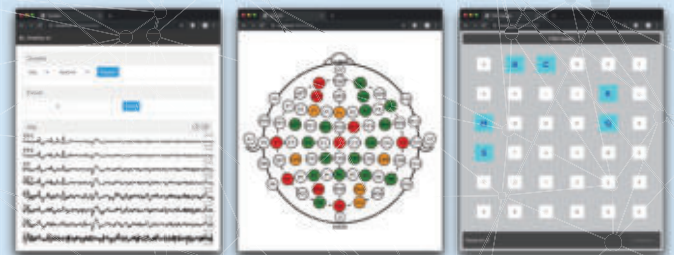

*Timeflux: an open-source framework for the acquisition and near real-time processing of signal streams*

**P. Clisson, R. Bertrand-Lalo, M. Congedo, G. Victor-Thomas, J. Chatel-Goldman**

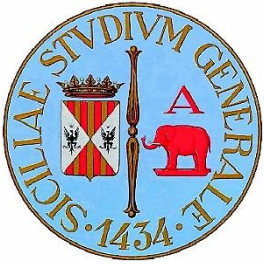

## Non-invasive brain stimulation in sleep disorders: from electrophysiology to neuromodulation

Giuseppe Lanza,<sup>1,2\*</sup> Rita Bella,<sup>3</sup> Raffaele Ferri<sup>1</sup>

<sup>1</sup> Clinical Neurophysiology Research Unit, Oasi Research Institute-IRCCS, Troina, Italy

<sup>2</sup> Department of Surgery and Medical-Surgical Specialties, University of Catania, Catania, Italy

<sup>3</sup> Department of Medical, Surgical and Advanced Technology, University of Catania, Catania, Italy

\* Submitting and presenting author – email address: giuseppe.lanza1@unict.it

Non-invasive brain stimulation (NIBS) is widely used for neuromodulatory purposes. When applied in sleep medicine, the main hypothesis explaining its effects concerns the induction of neural plasticity and the modulation of the strength of synaptic connections between the brain areas involved in sleep disorders. Recently, a multi-database-based search converges on the evidence that NIBS is safe and effective in insomnia, restless legs syndrome, and sleep deprivation-related cognitive deficits; limited data are available for sleep bruxism and REM sleep behavior disorder, whereas no relevant effect was observed in obstructive sleep apnea syndrome and narcolepsy. Some limitations, especially regarding the population studied and the stimulation protocols adopted, need to be considered, although the development of individually tailored neuromodulatory techniques is promising.

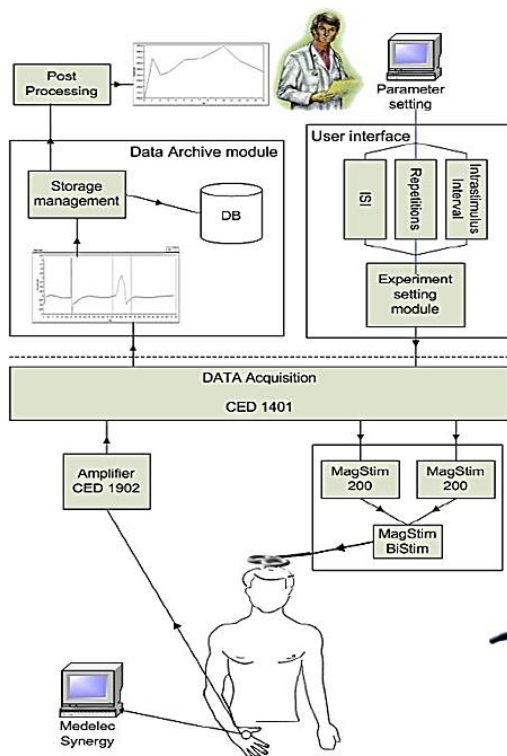

### An Interactive Tool for Customizing Clinical Transcranial Magnetic Stimulation (TMS) Experiments

A. Faro<sup>1</sup>, D. Giordano<sup>1</sup>, I. Kavasidis<sup>1</sup>, C. Pino<sup>1</sup>, C. Spampinato<sup>1</sup>, M.G. Cantone<sup>2</sup>, G. Lanza<sup>2</sup> and M. Pennisi<sup>2</sup>

IFMBE Proceedings 29, pp. 200–203, 2010.

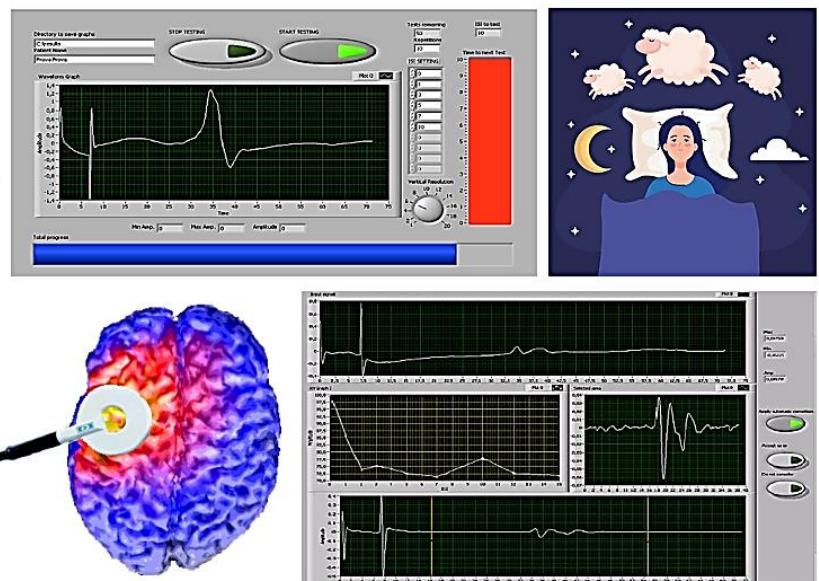

[1] Lanza G, DelRosso LM, Ferri R. Sleep and homeostatic control of plasticity. *Handb Clin Neurol.* 2022;184:53-72. doi: 10.1016/B978-0-12-819410-2.00004-7. PMID: 35034758.

[2] Lanza G, Cantone M, Lanuzza B, Pennisi M, Bella R, Pennisi G, Ferri R. Distinctive patterns of cortical excitability to transcranial magnetic stimulation in obstructive sleep apnea syndrome, restless legs syndrome, insomnia, and sleep deprivation. *Sleep Med Rev.* 2015 Feb;19:39-50. doi: 10.1016/j.smrv.2014.04.001. Epub 2014 Apr 13. PMID: 24849846.

[3] Lanza G, Fiscaro F, Cantone M, Pennisi M, Cosentino FII, Lanuzza B, Tripodi M, Bella R, Paulus W, Ferri R. Repetitive transcranial magnetic stimulation in primary sleep disorders. *Sleep Med Rev.* 2023 Feb;67:101735. doi: 10.1016/j.smrv.2022.101735. Epub 2022 Dec 8. PMID: 36563570.



# Wearable neural sensors based on epitaxial graphene for hands-free robotic control

Francesca Iacopi<sup>\*1,2</sup>, Shaikh Nayeem Faisal<sup>1</sup>, Nguyen Tien Thong Do<sup>1,2</sup>, Daniel Leong<sup>1,2</sup> and Chin-Teng Lin<sup>1,2</sup>

<sup>1</sup>Faculty of Engineering and Information Technology, University of Technology Sydney, Ultimo, NSW, 2007, Australia

<sup>2</sup>Australian Artificial Intelligence Institute, FEIT, University of Technology Sydney, Ultimo, NSW 2007, Australia

<sup>3</sup>Australian Research Council Centre of Excellence for Transformative Meta-Optical Systems, University of Technology Sydney, Ultimo, NSW 2007, Australia

[\\*francesca.iacopi@uts.edu.au](mailto:francesca.iacopi@uts.edu.au)

Recent simultaneous advances in Neurosciences and Artificial Intelligence have paved the path to the use of electroencephalography (EEG) as a non-invasive platform for brain-computer interfaces (BCIs) [1]. The availability of suitable dry sensors has become one of the main bottlenecks in the further progress of EEG-based BCI technologies. Dry sensors tend to show a high contact impedance with the skin due to their strong capacitive contact component, limiting an accurate read-out of the biopotentials at the scalp [2]. The use of 2D materials for neural sensors open new promising solutions to the sensor bottleneck, although reliable contact through hairy scalp sites is still an open challenge [3].

We demonstrate the use of epitaxial graphene on silicon carbide on silicon as dry EEG sensors for a wearable brain-machine interface (BMI) system which is reliable upon long-term usage. The produced sensors are wafer-thin, highly biocompatible, and show a lower contact impedance as compared to their bulkier commercial sensor counterparts and are remarkably resilient to corrosion in saline environments.

The BMI evaluation used a steady-state visual evoked potential paradigm (SSVEP), presenting the individual with up to 6 command options to control hands-free the movement of a robotic quadruped. We have demonstrated up to 94% accuracy in the lab using 6 graphene sensors mounted on a rudimentary helmet in the presence of 5mm length hair.

*We acknowledge funding from the Commonwealth of Australia, through the Defense Innovation Hub Contract P18-650825.*

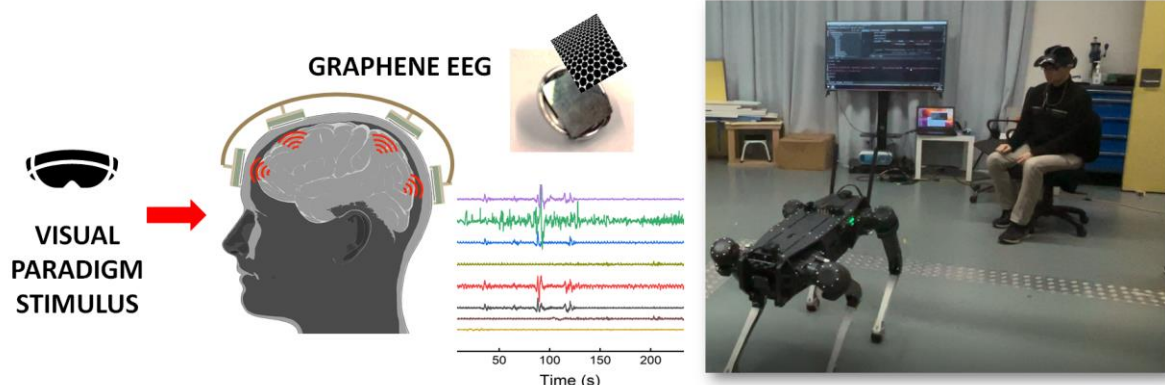

[1] F Iacopi and CT Lin, A perspective on electroencephalography sensors for brain-computer interfaces, submitted to Prog.Biomed.Eng., July 2022.

[2] G Lia, S Wang, YY Duan, Sensors & Actuators: B. Chemical 277, 250–260, 2018.

[3] SN Faisal, F Iacopi, ACS Applied Nano Materials 5 (8), 10137-10150, 2022.

[4] SN Faisal, M Amjadipour, K Izzo, JA Singer, A Bendavid, CT Lin, F Iacopi Journal of Neural Engineering 18 (6), 066035, 2021.

## **Neurofeedback to enhance response to hypnosis in individuals with multiple sclerosis**

Mark P. Jensen, PhD  
Department of Rehabilitation Medicine  
University of Washington  
Seattle, Washington USA

Prior research indicates that resting state theta power predicts response to hypnosis treatment, suggesting the possibility that neurofeedback to enhance theta power might enhance response to clinical hypnosis. To examine this possibility in a pilot study, 22 individuals with multiple sclerosis and pain or fatigue were randomly assigned to five sessions of hypnosis treatment alone or five sessions of hypnosis combined with 10 sessions of neurofeedback. The results indicated larger improvements in pain intensity, sleep disturbance, and depression in participants who received the combined treatment than who received HYP alone. No between-group differences in fatigue were found. The results are consistent with the possibility that NF could be used to enhance response to hypnosis interventions.



# The *BitBrain* method for learning and inference at the edge

Michael Hopkins<sup>\*,1</sup> and Jakub Fil<sup>1</sup>

<sup>1</sup>The University of Manchester  
<sup>\*</sup>*michael.hopkins@manchester.ac.uk*

We present an innovative working mechanism (the *SBC memory*) and surrounding infrastructure (*BitBrain*) based upon a novel synthesis of ideas from sparse coding, computational neuroscience and information theory that enables fast and adaptive learning and accurate, robust inference. The mechanism is designed to be implemented efficiently on current and future neuromorphic devices as well as on more conventional CPU and memory architectures. An example implementation on the SpiNNaker neuromorphic platform, world's largest real-time brain simulator, has been developed and results are presented.

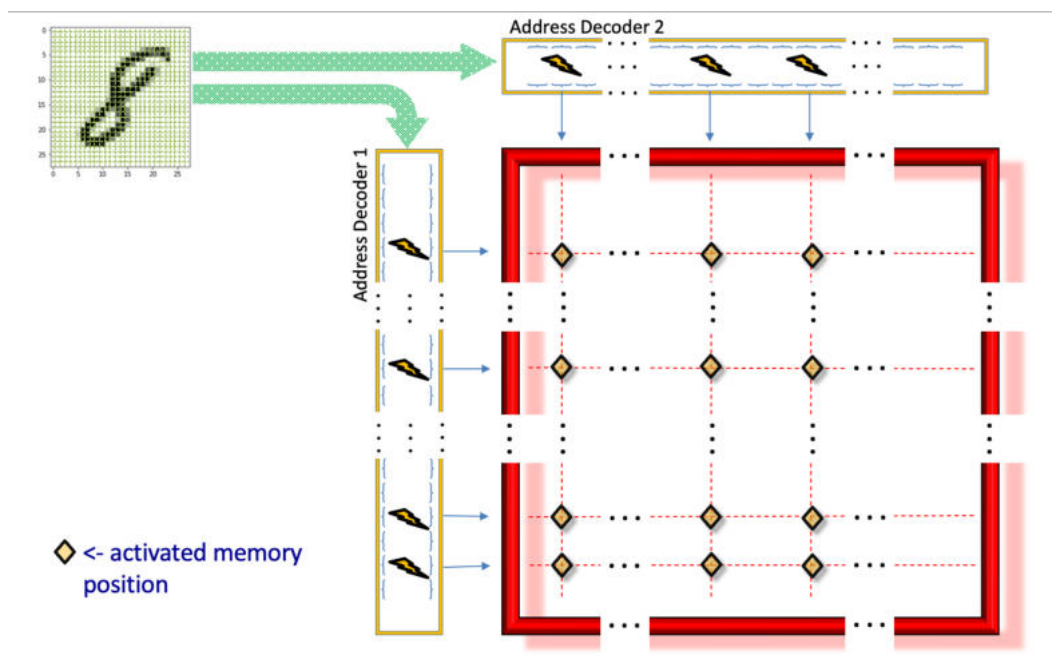

The SBC memory stores coincidences between features detected in class examples in a training set, and infers the class of a previously unseen test example by identifying the class with which it shares the highest number of feature coincidences. A number of SBC memories may be combined in a *BitBrain* to increase the diversity of the contributing feature coincidences. The resulting inference mechanism is shown to have excellent classification performance on benchmarks such as MNIST and EMNIST, achieving classification accuracy with single-pass learning approaching that of state-of-the-art deep networks with much larger tuneable parameter spaces and much higher training costs. It can also be made very robust to noise. Moreover, we demonstrate that *BitBrain* can be applied to other types of data also in multi-modal fashion, for example event-based inputs, audio, codes, EMG and others.

*BitBrain* is designed to be very efficient in training and inference on both conventional and neuromorphic architectures. It provides a unique combination of single-pass, single-shot and continuous supervised learning; following a very simple unsupervised phase. Accurate classification inference that is very robust against imperfect inputs has been demonstrated. These contributions make it uniquely well-suited for edge and IoT applications.





POLITECHNIKA  
GDAŃSKA



WYDZIAŁ ELEKTRONIKI,  
TELEKOMUNIKACJI  
I INFORMATYKI

# BRAINBOT

## Brain-Machine Interface for EEG-controlled vehicle

### EEG

Real Time Motion Intent  
Prediction Interface using  
Biosemi EEG System with  
Accuracy up to 83%

### AI Model

AI Powered Neural Network Model  
Trained on Personalized Data  
collected from EEG

### JetBot

Wifi Robot steering using real time EEG data  
Obstacle Detection and Avoidance system  
based on Midas Depth Detection Neural  
Model and Camera Vision

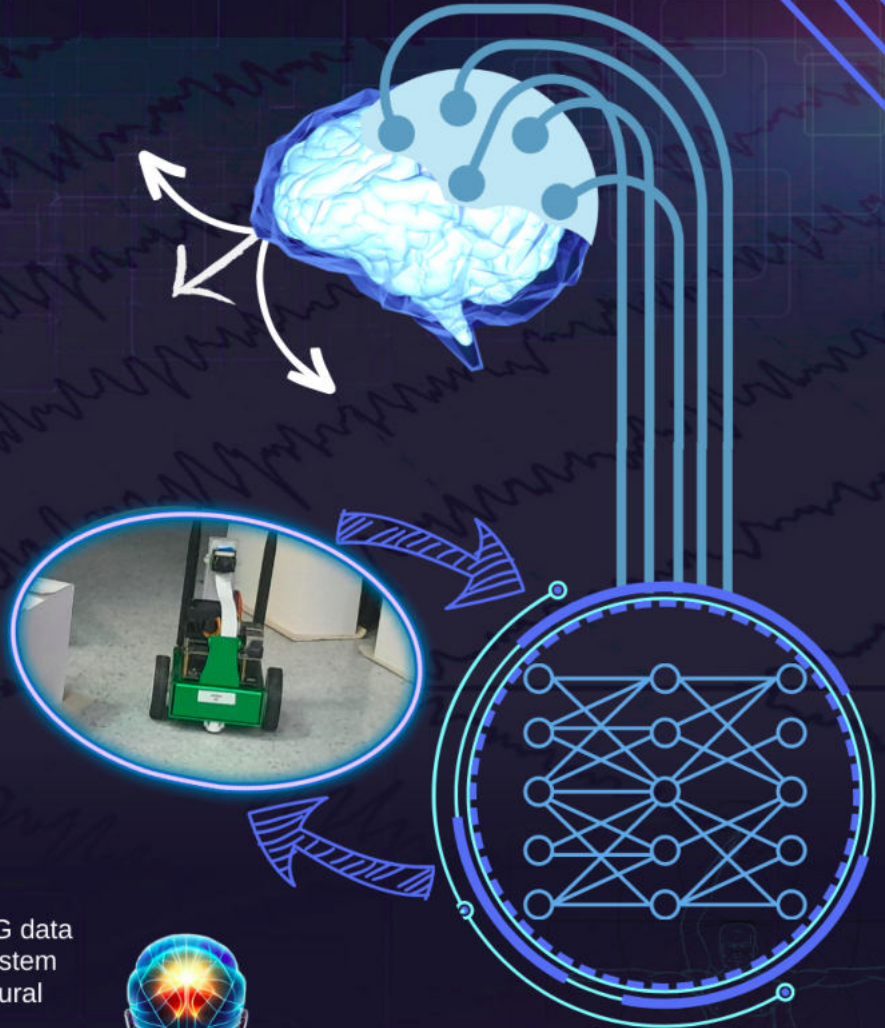

Authors: Nikodem Matuszkiewicz, Jakub Kwiatkowski, Piotr Durawa, Aleksander Madajczak  
Machine Learning, Faculty of Electronics, Telecommunications and Informatics, Gdańsk University of  
Technology Project supervisor: Tomasz Kocejko, PhD.  
Contact: s175867@student.pg.edu.pl tomkocej@pg.edu.pl



Fundusze  
Europejskie  
Polska Cyfrowa



Rzeczpospolita  
Polska



Unia Europejska  
Europejski Fundusz  
Rozwoju Regionalnego



Projekt współfinansowany ze środków Unii Europejskiej w ramach Europejskiego Funduszu Rozwoju Regionalnego.

Program Operacyjny Polska Cyfrowa na lata 2014-2020.

Oś priorytetowa nr 3 „Cyfrowe kompetencje społeczeństwa”, działanie nr 3.2 „Innowacyjne rozwiązania na rzecz aktywizacji cyfrowej”.

Tytuł projektu: „Akademia Innowacyjnych Zastosowań Technologii Cyfrowych (AI Tech)”.

# IDUN Technologies

IDUN Technologies is a Swiss neurotechnology company developing the IDUN Guardian, the first commercially available brain analytics platform comprising in-ear EEG earbuds and a cloud-based solution

[Read More](#) >



## IDUN Guardian Earbuds

The IDUN Guardian Earbuds are a consumer-friendly brain-computer interface with signal quality high enough to enable EEG-based interventions for multiple applications.



[Read More](#) >

## IDUN Guardian Software

The IDUN Guardian Software allows for processing and interpreting brain signals on the cloud, offering valuable decoded user insights to enterprise customers through API.

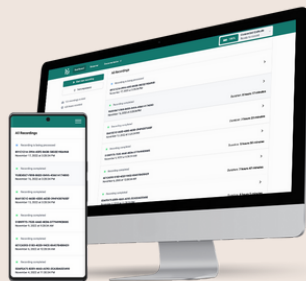

[Read More](#) >

## High-Quality Data

- Data has been validated and is comparable to full-scalp EEG data
- Standard EEG neuromarkers such as ASSR, Alpha, SSVEO etc. can be accurately identified
- Sleep-based neuromarkers such as K-complexes, sleep spindles, slow waves etc. can be accurately identified

## Use Cases

By integrating EEG sensors into earbuds, the most widely adopted wearable, the IDUN Guardian can monitor and process accurate brain activity in everyday situations. This data can be used in a range of use cases such as:

- Long-term sleep monitoring
- Personalized hearing aids
- Tracking focus and cognitive workload

# INNER PSYCHOPHYSICS IP LLC

THE SENSE ELEMENT ENGAGEMENT  
PROCESS

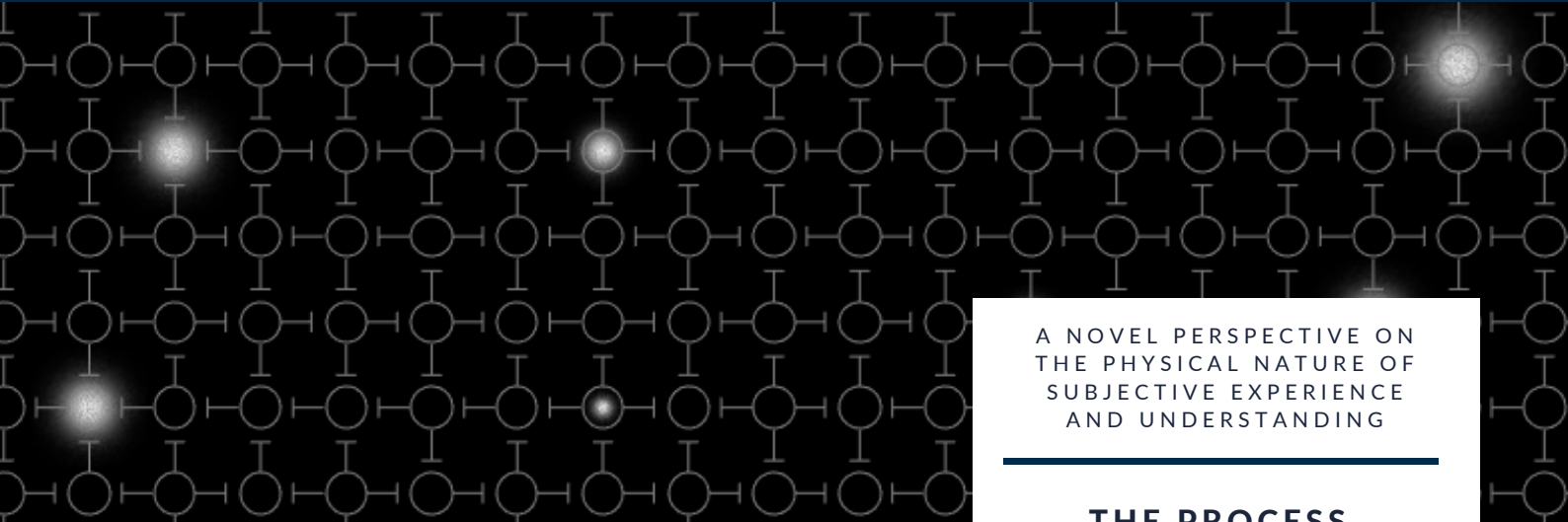

A NOVEL PERSPECTIVE ON  
THE PHYSICAL NATURE OF  
SUBJECTIVE EXPERIENCE  
AND UNDERSTANDING

## THE PROCESS

## A BUILDING BLOCK FOR NEURAL NETWORK ARCHITECTURE BASED ON HUMAN VISION

### RESHAPING CORTICAL PROSTHETIC VISION AND AI

Current artificial intelligence based on deep learning has problems. Each of these AI systems can only be used in situations for which it's designed, and they make mistakes even in such situations. Anything that's too different from their training sets causes issues. This isn't surprising, because their construction is not based on a notion of how actual understanding arises from neural interactions.

Current cortical prostheses have problems, too. Cortical prosthetic vision researchers struggle to produce useful systems because there's no notion of how visual experiences arise from neural interactions.

We need a solution to these problems that's based on a testable theory of experience and understanding.

<https://innerpsychophysicsip.com>

Identify the aspect of experience which is to be engaged by a neuromorphic neural network and conceptualize it as a sensible spatiotemporal pattern

Model the pattern and describe how it emerges, i.e., its self-organization

Create simulations of the systems of synaptic interactions and use the results to create a physical instantiation of the system of synaptic interactions in a neural network composed of neuromorphic hardware

Predict how modification of a parameter or parameters of the neural network should produce a specified change in the aspect of human experience and use the simulations and neuromorphic neural network to develop a device that is predicted to modify it

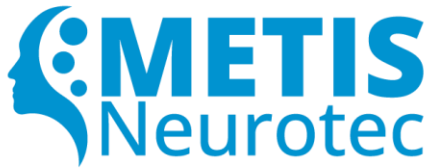

Worldwide, only 20-50% of all cases of dementia are being diagnosed. Therefore, there is a significant deficit in recognizing and treating the neurological disorder. However, almost 90% of doctors and patients surveyed demand early diagnosis to react to associated changes in care and everyday life.



For this reason, the German federal government approved a national dementia strategy in 2020. However, tools for the early treatment of dementia are not widely available.

According to recent studies, around one-third of all cases of dementia can be prevented or at least positively influenced in their course by timely treatment of specific risk factors. The starting point for METIS is the scientific consensus that neurological disorders such as dementia are multi-factorial processes reflected in declining memory performance due to individual risk profiles.

**METIS** develops a digital platform that accompanies a multi-stage process to provide low-threshold access to individualized treatment strategies for neurodegenerative diseases in an outpatient setting. With the help of digital platform-based methods and technologies for controlling risk factor-based intervention strategies, this treatment process is integrated into a mobile support solution and accompanied by various tools. These include the use of AI for the personalization of treatment of patient specific risk-profiles and direct contact with medical professionals. The system is completed by employing modern wearables to fine-tune the patient's holistic health profile and intervention plan.

**Help us to stop dementia.**



**Dr. Markus Schinle**  
Schinle@MetisNeurotec.com



**Marius Gerdes**  
Gerdes@MetisNeurotec.com



**Dr. Simon Stock**  
Stock@MetisNeurotec.com

get in contact with us

we make EEG & EMG-based  
**BIOSENSING DEVICES**

We help research, tech and robotics professionals to leverage neuroscience in a practical and reliable way.

## products



### arc

6+2 channel wireless easy-to-use EEG headset with really fast set up time and semi-dry conductive fabric electrodes.



### armband

8+2 channel EMG armband for developing gesture- and motion-based controller for a wide range of applications.

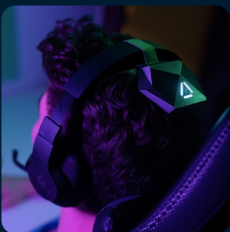

### strip

4+2 channel wireless easy-to-use headphone accessory to transform any headphone into a EEG-based brain-sensing device.

## softwares

### visualizer & SDK BrainFlow-based

- visualize & save
- raw data
- many programming languages

## services

### custom-made biosensing devices

- special electrodes
- additional sensors (SpO2, GSR, HRV)
- customized design

● Real-world  
research

● Real-life  
applications

● Human-computer  
interfaces

**get in touch:** [info@mindrove.com](mailto:info@mindrove.com)  
[mindrove.com](http://mindrove.com)

# Join the leading and most published mobile fNIRS research platform.



From high-end entry-level systems to high-density whole head.



NEW: Fully integrated physiology NIRxWINGS (pulse oximetry (PPG), heart-rate, heart-rate variability (HRV), oxygen saturation (SpO2), respiration, temperature, galvanic skin response (GSR), and bipolar signals such as EMG and ECG).



Superior short-channel solution 8mm & sensor-level motion sensors.



Multimodal integration with EEG, TMS, fMRI, eye-tracking, and more.



Laser and APD extension for full MR compatibility.



Free support by fNIRS experts, our goal is to get you to publish fast.



NEW: Satori commercial fNIRS software in cooperation with Brain Innovation.



Anatomically correct baby and infant head models.



# F1 Mobile EEG

EEG recording in clinic, practice and at home



Distribution by simul consulting  
contact@simul-consulting.com  
+49 6196 / 90254-34

Funded by:



on the basis of a decision  
by the German Bundestag



## Dry Electrode Mobile EEG Headset

Up to 37 channel EEG device designed for medical and research application

The F1 Headset is a battery-operated system, designed to measure the electrical activity along the scalp (EEG, electroencephalogram), by using the dry electrode to scalp connection, without skin preparation. The measured signal is digitized and transmitted to a PC. During a recording the user can easily mark an event such as dizziness to make it traceable within the recorded data by using the RF Wrist Marker that is conveniently worn like a watch. A local PC is used for signal processing and analysis.

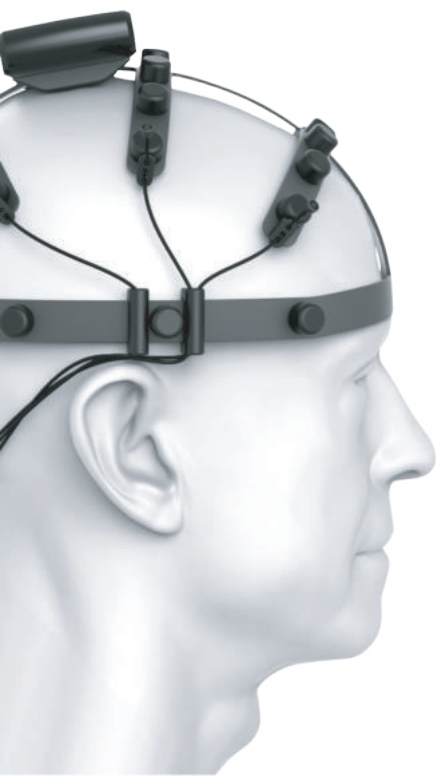

### Certificate

CE certificate according to Directive 93/42/EEC on Medical Devices (MDD)



ISO 13485:2016

- Dry electrodes without contact gel
- Suitable for home monitoring
- Easy usage for patient or nurse
- Battery-powered
- Registration and data storage
- Covering the 10-20 System
- Disinfectable
- CE-certified as medical device
- Conforming with clinical requirements
- Impedance measurement
- Removable Li-ion battery, 3.85 V, 2100 mAh
- Battery Life: > 4 h

Scan for more info

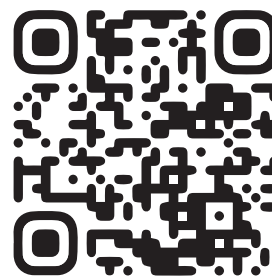

www.telemedi.tech  
info@telemedi.tech

TeleMedi GmbH  
Danzstrasse 1, 39104 Magdeburg, Germany





SEE YOU IN  
2024!

**11-12 JUNE 2024. BERLIN, GERMANY**